



The NEW FAR 23

2017 Design Delegation Holders' Seminar

David Gill
Team Leader Airworthiness

May 2017

The New FAR23 / CS23

Performance Based Rule – Result:

67 NEW Objective requirements

replacing

377 detailed Specific Design requirements

MOC moved to Industry Consensus

Standards (ASTM)

Why we needed the new Rule

New Model Introductions

4-Seat Entry-Level Airplanes

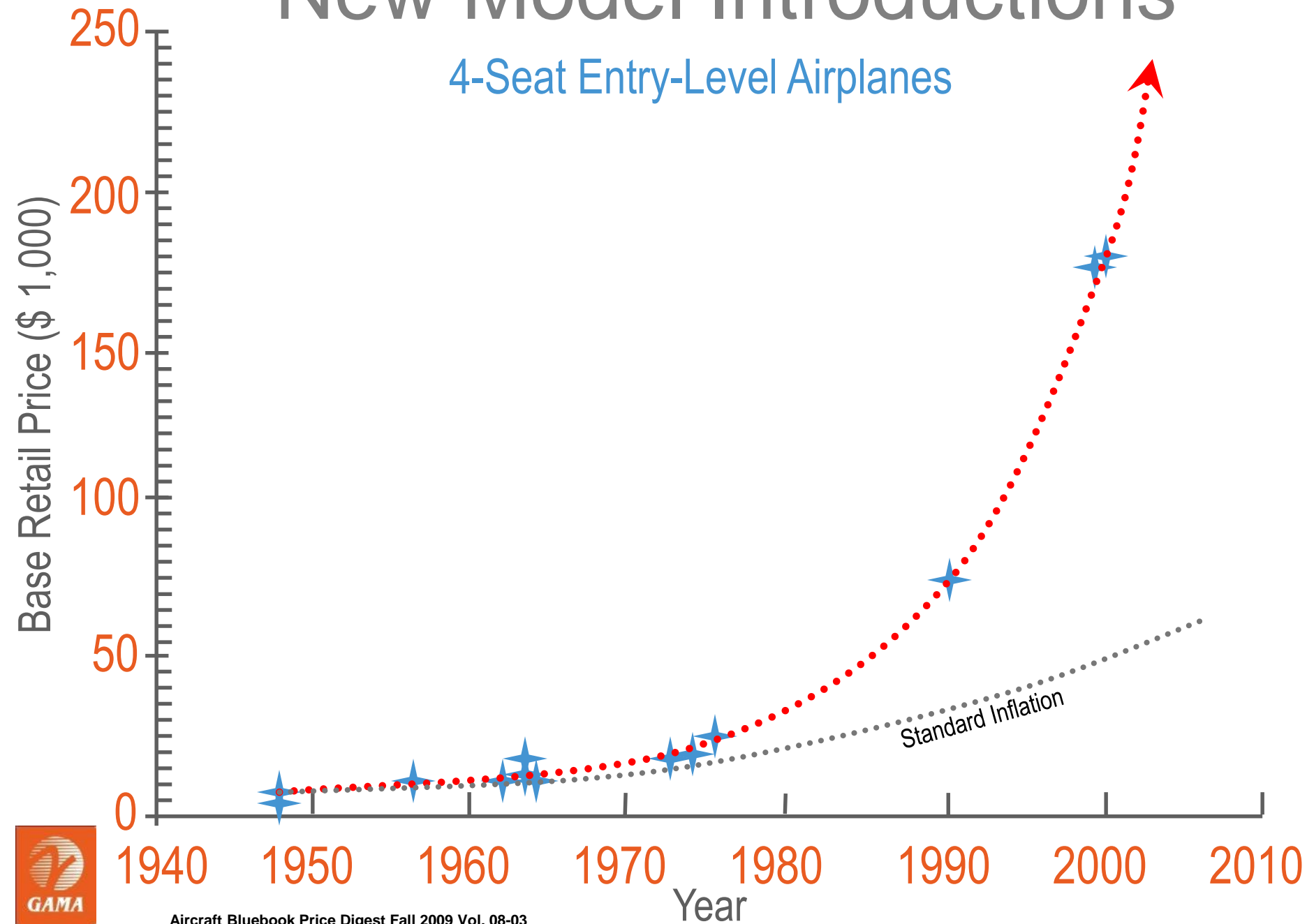

Part 23 Piston Airplanes Manufactured Annually

■ - Piston Airplanes
 ■ - Turboprop Airplanes
 ■ - Turbojet Airplanes

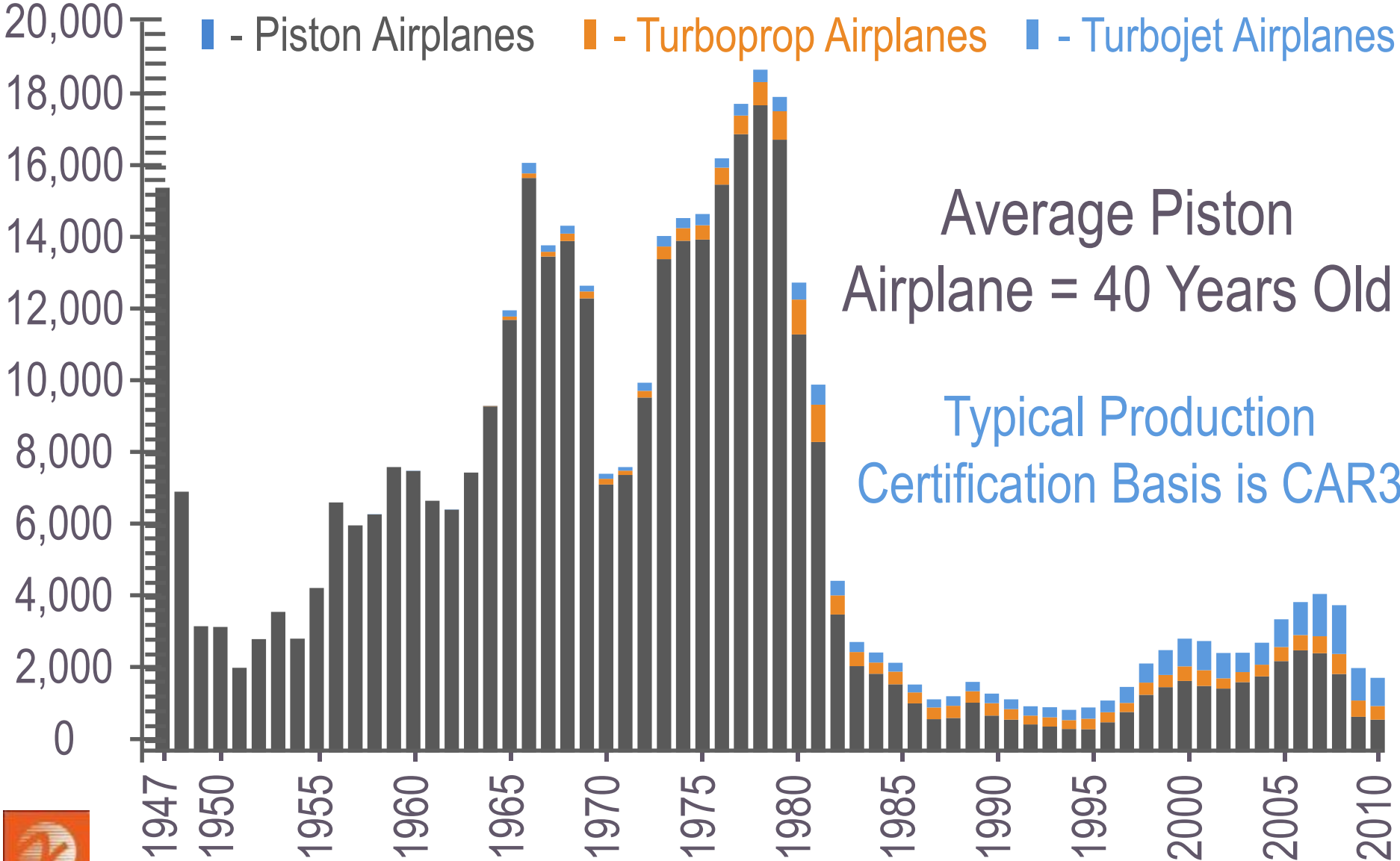

Average Piston
Airplane = 40 Years Old

Typical Production
Certification Basis is CAR3



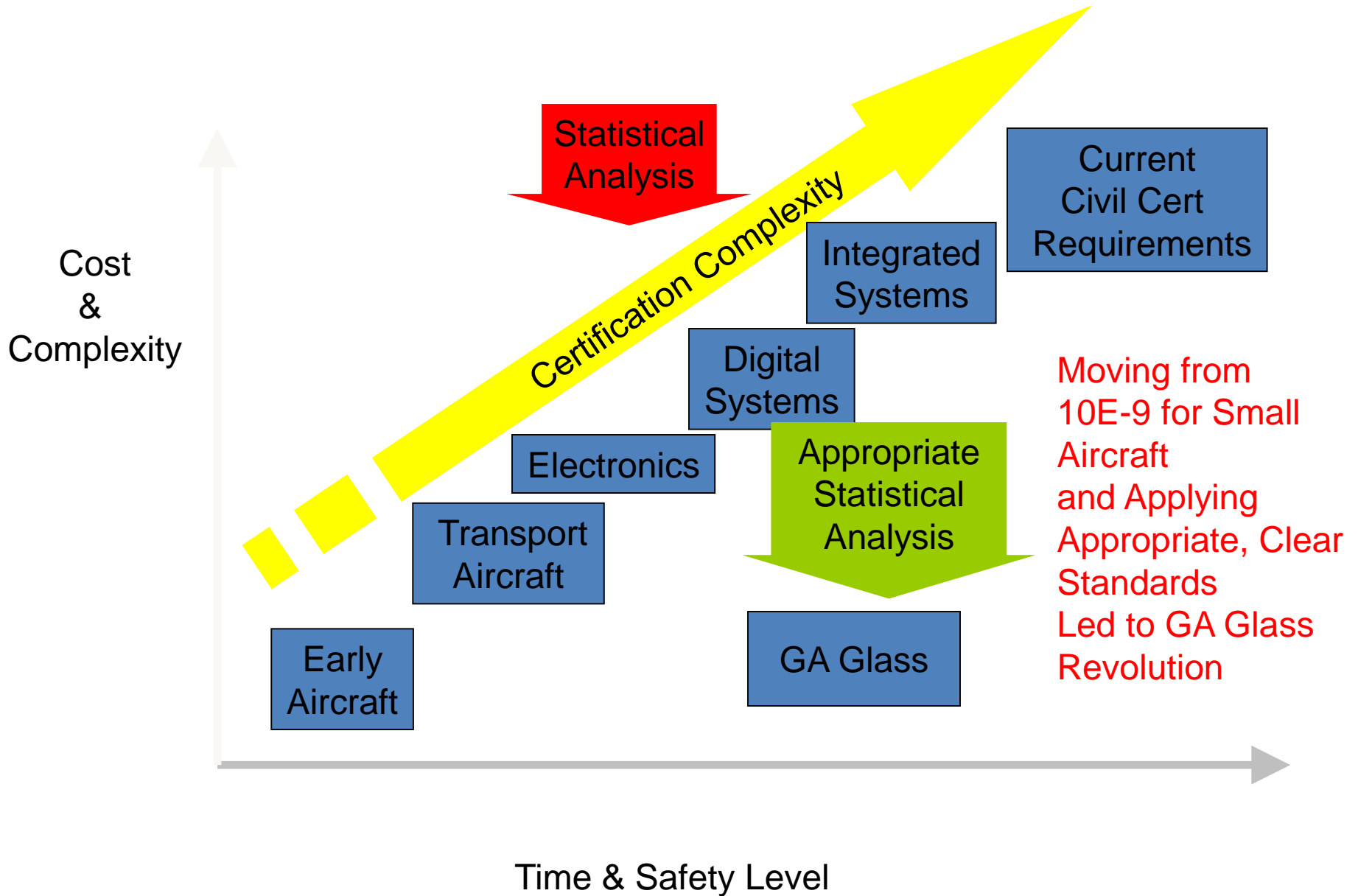

Why we need to re-organize Part 23



1955

2005



Why we need to re-organize Part 23



1955

2005



Why we need to re-organize Part 23



1956

2006



History of Development

- FAA Certification Study
- Part 23 Aviation Rulemaking Committee
- Final Report April 2013
- *“Double the safety for half the cost”*
- Reorganize part 23 based on performance and complexity instead of weight and propulsion
- Create tiering in Part 23
 - First tier: low-complexity, low-performance.
 - Next tier: medium-complexity, medium-performance
 - Highest tier: high-complexity, high-performance

FAR 23 Re-Write Principle ASTM F44 Committee

- Rules to be generalised requirements
- Detailed requirements to be contained in separate industry consensus standards
- ASTM selected to be the sponsoring organisation
- Initial “Revision 0” of standards to be:
 - *Current FAR 23 wording*
 - *Provision for “tiering”*
 - *Two improved rule areas:*
 - *Stalling prevention*
 - *Flight in icing conditions*

Why Are We Doing This?

- **Safety** - Reduce the General Aviation fatality rate.
- Respond to the stagnated certification of new part 23 entry level airplanes and the displacement of certified airplanes by experimental and light sport aircraft.
- Facilitate the installation of safety enhancing technologies in new and existing fleet product designs to increase safety.
- Utilize Industry Consensus-based Standards to assist applicants in complying with regulations and for international acceptance
- Provide improved agility to address new technology.
- Streamline the approval and reduce regulatory cost burdens.

Why Are We Doing This?

Big Picture

- The safety continuum laid the foundation needed for small aircraft
- Then we needed an engineering-based requirements architecture that doesn't require rulemaking to keep up with technology - performance-based rules
- Wanted to reduce the need for workarounds when applicants bring new products to the market
- Wanted to encourage applicants to try new technology, many of which are safety enhancing

Why are we doing this?

- Rulemaking for small airplanes takes almost a decade
- Part 23 Amendment 62 added requirements for jets in 2012
- That's approximately a half-century after their introduction



MS.760 Paris – FAA TC 1958



Lear 23 – FAA TC 1964

Why Are We Doing This?

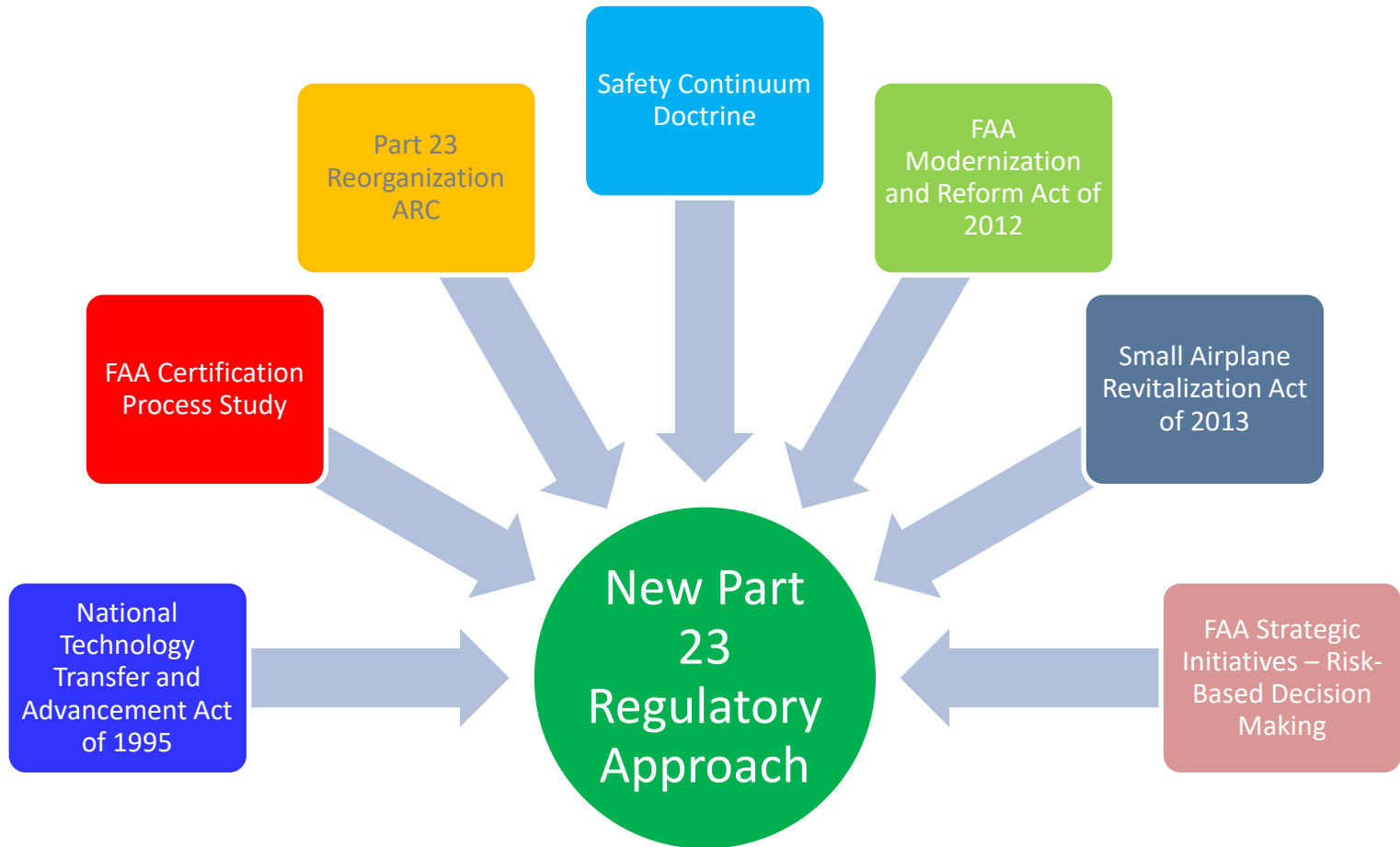

Why Are We Doing This

**Safety
and
Cost**

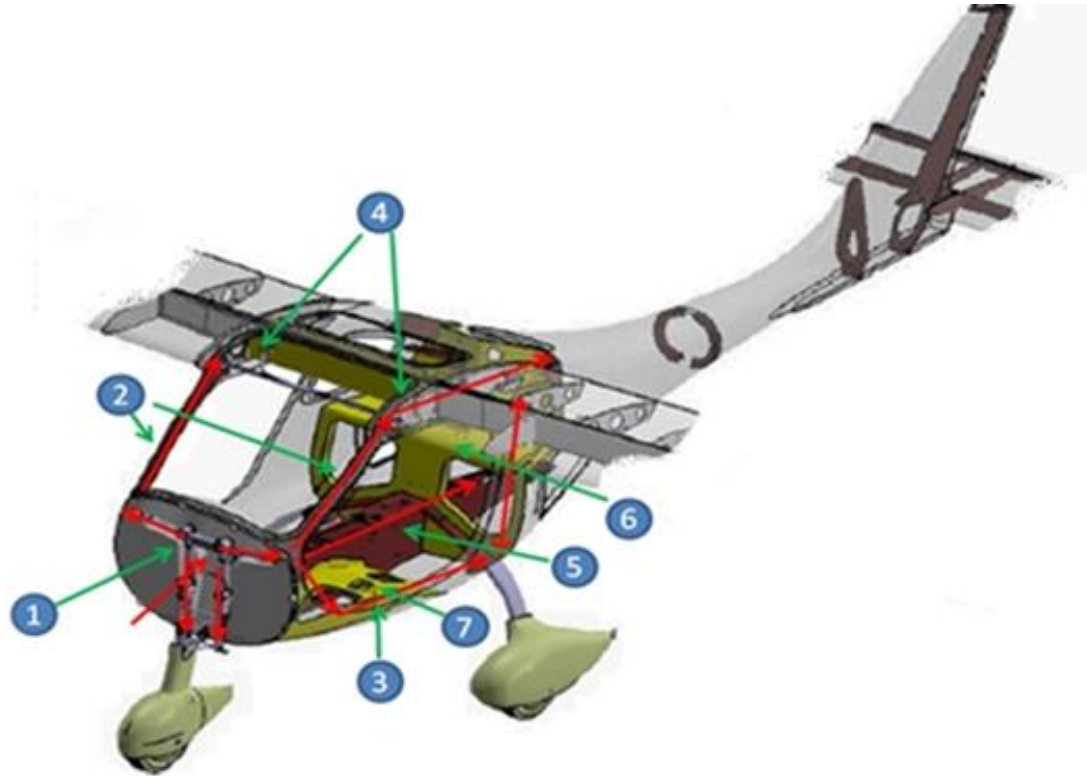

Why Are We Doing This



Adaptability and
Agility



Objective of the reorganised CS-23

CS-23 should provide requirements that:

1. bring safe designs for aeroplanes
2. support innovation
3. are proportionate with risks
4. can follow technological developments
5. lower administrative burden

Part 23 Reorganization ARC

- Revise CFRs into safety/performance based Part 23 requirements that are clear and logically organized
- Move more prescriptive MOC into internationally accepted industry standard
- Eliminate weight and propulsion divisions and use performance based divisions
- Revise or eliminate categories where possible
- Incorporate CS-VLA as the entry level Part 23 airplane to encourage manufacturers to move from LSA and Experimental into Part 23.

Part 23 Reorganization ARC

- Proposed maintaining current level of safety except for Loss of Control (LOC) and Icing
- The prescriptive requirements in current rule are not lost, they are moving to means

Part 23 ARC Proposal a Win-Win Approach

- FAA gets to address their top cause of fatal accidents and improve crashworthiness
- Industry gets cost savings thru efficiencies in rule and ASTM standards as well as streamlined processes

Rulemaking Cooperation Process - Pilot Project Part 23 / CS-23 Reorganisation

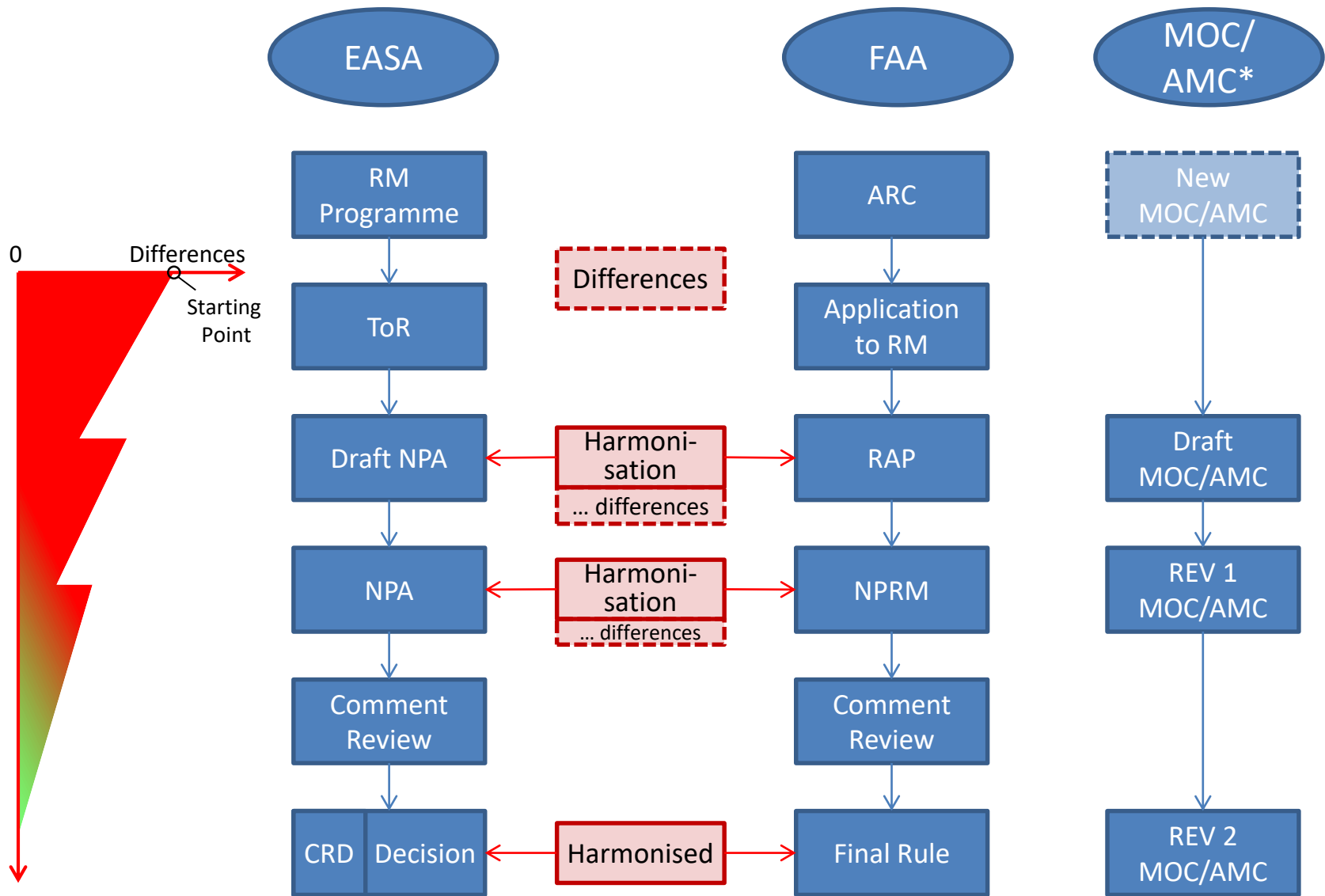

* MOC/AMC (means of showing compliance) consists of existing and/or reorganised means of showing compliance to the rules

What's the Status?

Current Schedule

Item	Status
Final Rule	Publication date December 2016
AC 23.2010	Published
ASTM Standards	Revised/accepted Aug 2017
Accepted MOC Website	Aug 2017
EASA Harmonization, Other NAA's	CS-23 published April 2017
Effective Date for Final Rule	August 30 th 2017



The new FAR 23 CS 23 Rules



67 NEW objective requirements replace 377 requirements in CS-23 and CS-VLA

Proportionality is created in the AMC taking into account design and operational specific criteria

And if applicable:
A proportionate accepted safety level



In general: No longer Prescriptive

➤ Old:

➤ CS 23.1061 Installation (Liquid Cooling)

(b) *Coolant tank*. The tank capacity must be at least 3·8 litres (0·83 Imperial gallon/1 USgallon), plus 10% of the cooling system capacity. In addition –

➤ New:

➤ CS 23.2435 Powerplant installation support systems

(a) Powerplant installation support systems are all systems whose direct purpose is to support the powerplant or the energy storage device in its intended function as part of the powerplant installation.

....

(c) Powerplant installation support systems are designed for the operating conditions applicable to the location of installation. ...

➤ Plus ASTM standard



Engine and Propeller

- ▶ It is no longer required to have engine and propeller certificated
 - ▶ CS-23.2400 Powerplant installation
 - (a)...
 - (b) Each aeroplane engine, propeller and APU must be type certificated, or meet accepted specifications.

- ▶ Normally a certificate for the engine and propeller is expected, but for future designs this might not be necessary (electric motor as part of design, ...)



Aeroplane Categories are translated

- In the current CS-23 we have four Airplane Categories
 - Normal, Utility, Aerobatic and Commuter
 - This separation into categories made sense in earlier times, but it doesn't reflect nowadays needs anymore, since everything is more and more mixed (system wise)

- In the new CS-23 we have four Certification Levels
 - CS-23.2005 Certification of Normal Category Aeroplanes
 - (b) Aeroplane certification levels are:
 - (1) Level 1 — for aeroplanes with a max seating config of **0 to 1 pax**
 - (2) Level 2 — for aeroplanes with a max seating config of **2 to 6 pax**
 - (3) Level 3 — for aeroplanes with a max seating config of **7 to 9 pax**
 - (4) Level 4 — for aeroplanes with a max seating config of **10 to 19 pax**



Aeroplane Performance Levels

- In addition the new CS-23 knows different aeroplane performance levels
 - CS-23.2005 Certification of normal category aeroplanes
 - (c) Aeroplane performance levels are:
 - (1) Low speed — for aeroplanes with a V_{NO} or $V_{MO} \leq 250$ Knots Calibrated Airspeed (KCAS) or a $M_{MO} \leq 0.6$.
 - (2) High speed — for aeroplanes with a V_{NO} or $V_{MO} > 250$ KCAS or an $M_{MO} > 0.6$

International Harmonisation

CS-23/Part 23 harmonisation status

FAA Part 23

FAA published the Part 23 Amendment 64 final rule that will become effective on 30 August 2017

8 Month after the publication date, in order for the FAA to:

- introduce change management. This will allow training of FAA staff and industry engineers,
- development of guidance material and new means of compliance
- and further harmonisation.

Due to the ex parte restrictions it has not been possible for the FAA to discuss, share or elaborate on the various inputs during the rulemaking process which unavoidably has led to an uncoordinated interpretation of comments and conclusion.

EASA CS-23

- NPA 2016-05 published on 23 June 2016
- Consultation ended 30-09-2016
- 25 entities provided 318 comments
- **CS-23 Amendment 5 issued 1 April 2017**

Are we harmonised? CS-23 Amendment 5/Part 23 Amendment 64

➤ Distinguish between harmonisation of:

- rule/requirements
- Acceptable Means of Compliance

Status of rule/requirement harmonisation:

- + Coordination between EASA and FAA is ongoing
- + Numbering & titles close to full harmonisation

Main structural differences

- 23.2555 Installation of recorders
- 23.2625 Instructions for continued airworthiness
- Establishing **which** information in each subpart (e.g. 23.2170 Operating limitations) and define **how** to present the information in crew interface (23.2605 Installation and operational information)

➤ Objective:

- Aim for a common intent that allows the use of the same AMC
- Allow innovation

Are we harmonised? CS-23 Amendment 5/Part 23 Amendment 64

Status of AMC harmonisation:

- Coordination between stakeholders, including EASA and FAA is ongoing
- Three (EASA) AMC anticipated:
 1. Referring back to CS-VLA Amendment 1 (To avoid disconnect with existing Cert. basis)
 2. Referring back to CS-23 Amendment 4 (To avoid disconnect with existing Cert. basis)
 3. Referring to ASTM International F44 standards (Living documents)

The initial list of acceptable ASTM F44 standards is build from combining Part-23 Amendment 62, CS-23 Amendment 4 and CS-VLA Amendment 1.

These consensus standards are intended to provide therefore the “building blocks” with proportionality from the current CS-23 and CS-VLA.... and future innovations

•	CS-23 amendment 5	Part 23 Amendment 64
•	SUBPART A — GENERAL	Subpart A—General
•	CS 23.2000 Applicability and definitions	23.2000 Applicability and definitions.
•	CS 23.2005 Certification of normal-category aeroplanes	23.2005 Certification of normal category airplanes.
•	CS 23.2010 Accepted means of compliance	23.2010 Accepted means of compliance.
•	SUBPART B — FLIGHT	Subpart B—Flight
•	Performance	Performance
•	CS 23.2100 Mass and centre of gravity	23.2100 Weight and center of gravity.
•	CS 23.2105 Performance data	23.2105 Performance data.
•	CS 23.2110 Stall speed	23.2110 Stall speed.
•	CS 23.2115 Take-off performance	23.2115 Takeoff performance.
•	CS 23.2120 Climb requirements	23.2120 Climb requirements.
•	CS 23.2125 Climb information	23.2125 Climb information.
•	CS 23.2130 Landing	23.2130 Landing.
•	Flight Characteristics	Flight Characteristics
•	CS 23.2135 Controllability	23.2135 Controllability.
•	CS 23.2140 Trim	23.2140 Trim.
•	CS 23.2145 Stability	23.2145 Stability.
•	CS 23.2150 Stall characteristics, stall warning, and spins	23.2150 Stall characteristics, stall warning, and spins.
•		23.2155 Ground and water handling characteristics.
•	CS 23.2160 Vibration, buffeting, and high-speed characteristics	23.2160 Vibration, buffeting, and high-speed characteristics.
•	CS 23.2165 Performance and flight characteristics .. for flight in icing conditions	23.2165 Performance and flight characteristics .. for flight in icing conditions.
•	CS 23.2170 Operating limitations	
•	SUBPART C — STRUCTURES	Subpart C—Structures
•	CS 23.2200 Structural design envelope	23.2200 Structural design envelope.
•	CS 23.2205 Interaction of systems and structures	23.2205 Interaction of systems and structures.
•	STRUCTURAL LOADS	Structural Loads
•	CS 23.2210 Structural-design loads	23.2210 Structural design loads.
•	CS 23.2215 Flight load conditions	23.2215 Flight load conditions.
•	CS 23.2220 Ground and water load conditions	23.2220 Ground and water load conditions.
•	CS 23.2225 Component loading conditions	23.2225 Component loading conditions.
•	CS 23.2230 Limit and ultimate loads	23.2230 Limit and ultimate loads.
•	STRUCTURAL PERFORMANCE	Structural Performance
•	CS 23.2235 Structural strength	23.2235 Structural strength.
•	CS 23.2240 Structural durability	23.2240 Structural durability.
•	CS 23.2245 Aeroelasticity	23.2245 Aeroelasticity.
•	CS 23.2250 Design and construction principles	23.2250 Design and construction principles.
•	CS 23.2255 Protection of structure	23.2255 Protection of structure.
•	CS 23.2260 Materials and processes	23.2260 Materials and processes.
•	CS 23.2265 Special factors of safety	23.2265 Special factors of safety.
•	STRUCTURAL OCCUPANT PROTECTION	Structural Occupant Protection.
•	CS 23.2270 Emergency conditions	23.2270 Emergency conditions.
•	SUBPART D — DESIGN AND CONSTRUCTION	Subpart D—Design and Construction
•	CS 23.2300 Flight control systems	23.2300 Flight control systems.
•	CS 23.2305 Landing gear systems	23.2305 Landing gear systems.
•	CS 23.2310 Buoyancy for seaplanes and amphibians	23.2310 Buoyancy for seaplanes and amphibians.
•	OCCUPANT SYSTEM DESIGN PROTECTION	Occupant System Design Protection
•	CS 23.2315 Means of egress and emergency exits	23.2315 Means of egress and emergency exits.
•	CS 23.2320 Occupant physical environment	23.2320 Occupant physical environment.
•	FIRE AND HIGH ENERGY PROTECTION	Fire and High Energy Protection
•	CS 23.2325 Fire protection	23.2325 Fire protection.
•	CS 23.2330 Fire protection in designated fire zones	23.2330 Fire protection in designated fire zones and adjacent areas.
•	CS 23.2335 Lightning protection	23.2335 Lightning protection.
•	CS 23.2340 Design and construction information	



Federal Aviation
Administration

Part 23 Transition Workshop

Presented by: Small Airplane Directorate

Date: Spring 2017



Part 23 Transition Workshop

Main Goal

Provide engineers and project managers with guidance sufficient to prepare them for STC and TC projects using the new part 23 rule and means of compliance architecture.



Part 23 Transition Workshop

Detailed Goals

- Need to understand what's different from today
- Understand what options for accepted standards will be available and what should be available soon.
- Understand how ASTM fits
- Understand how to develop means of compliance when there isn't anything accepted for that requirement.
- AC 23.2010

Part 23 Transition Workshop

Detailed Goals

- Show that mixing the amendment levels on older airplanes is the same process as today.
- Show how MOCs can replace the current process of SCs and ELOSs for specific technologies.
- What has changed that might change the DER training.



What's Different?



What's Different? Safety Details

- Increasing stall handling characteristics requirements
 - Singles – tendency to depart
 - Light Twins – tendency to depart w/ asymmetric thrust
- Deleting one turn spin requirements for Normal category
- Removing specifics from dynamic seat rule
- Incorporating FIKI guidance into rule (Icing ARC rec)

What's Different? Example

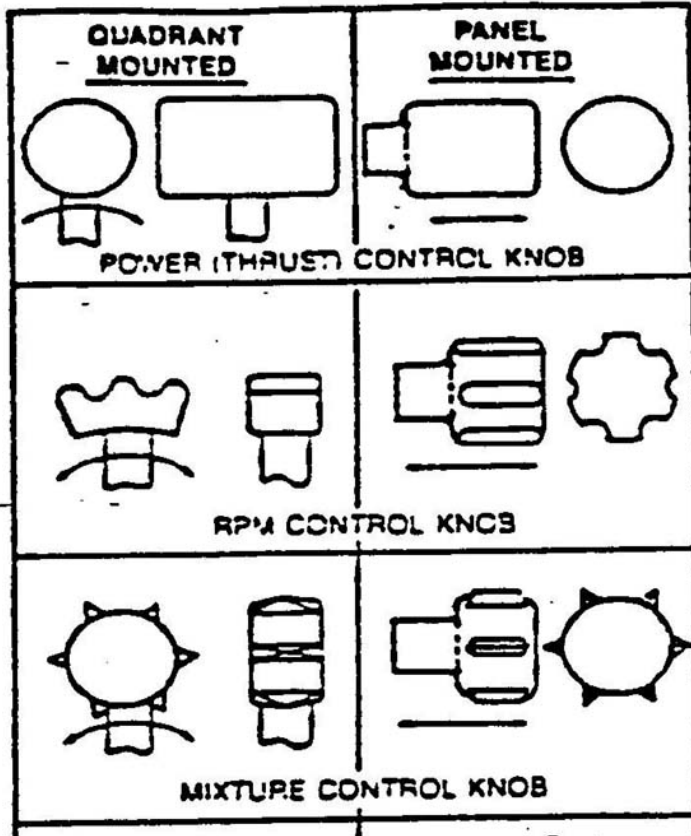

Memorandum

Date: APR 11 2008
From: Manager, Chicago Aircraft Certification Office, ACE-115C
To: Manager, Small Airplane Directorate, ACE-100
Prepared by: I
Subject: Equivalent Level of Safety to 14 Code of Federal Regulations (CFR) Part 23, § 23.777(d), Cockpit controls, and § 23.781(b), Cockpit control knob shape, for Cirrus Model SR22 Airplanes with Full Authority Digital Engine Control (FADEC)]; ACE-08-05

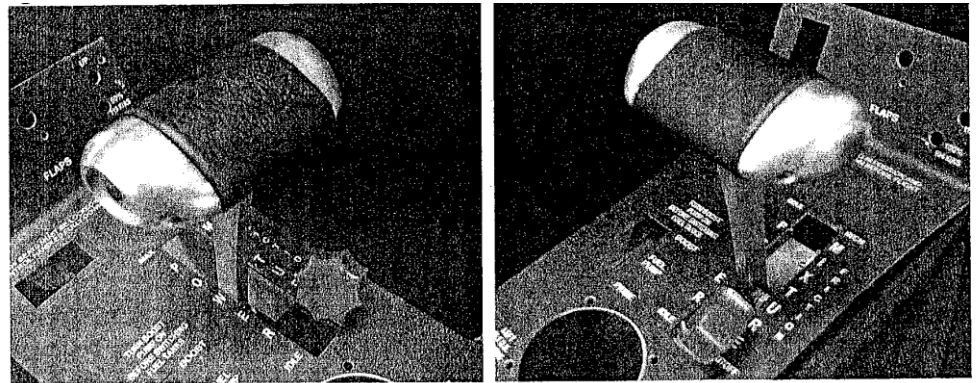

What's Different? New Rule

§ 23.2600 Flightcrew interface.

(a) The pilot compartment, its equipment, and its arrangement to include pilot view, must allow each pilot to perform his or her duties, including taxi, takeoff, climb, cruise, descent, approach, landing, and perform any maneuvers within the operating envelope of the airplane, without excessive concentration, skill, alertness, or fatigue.

(b) The applicant must install flight, navigation, surveillance, and powerplant controls and displays so qualified flightcrew can monitor and perform defined tasks associated with the intended functions of systems and equipment. The system and equipment design must minimize flightcrew errors, which could result in additional hazards

Just eliminated the need for paperwork

What's Different? Examples

How about FADEC?

- The current special conditions can be used as acceptable MOCs
- Eliminates the need to publish special conditions



What's Different? Examples

23.1397 Color specifications

Each position light color must have the applicable International Commission on Illumination chromaticity coordinates as follows:

(a) *Aviation red*--

"y" is not greater than 0.335; and

"z" is not greater than 0.002.

(b) *Aviation green*--

"x" is not greater than $0.440 - 0.320 y$;

"x" is not greater than $y - 0.170$; and

"y" is not less than $0.390 - 0.170 x$.

(c) *Aviation white*--

"x" is not less than 0.300 and not greater than 0.540;

"y" is not less than " $x - 0.040$ " or " $y_0 - 0.010$ ", whichever is the smaller; and

"y" is not greater than " $x + 0.020$ " nor " $0.636 - 0.400 x$ ";

Where " y_0 " is the "y" coordinate of the Planckian radiator for the value of "x" considered.





Stalling Behaviour

- We no longer look at the Spin
- Main focus is now on stalling behaviour



3.2 Analysis of accident statistics and reports

– Position of occurrences within traffic pattern

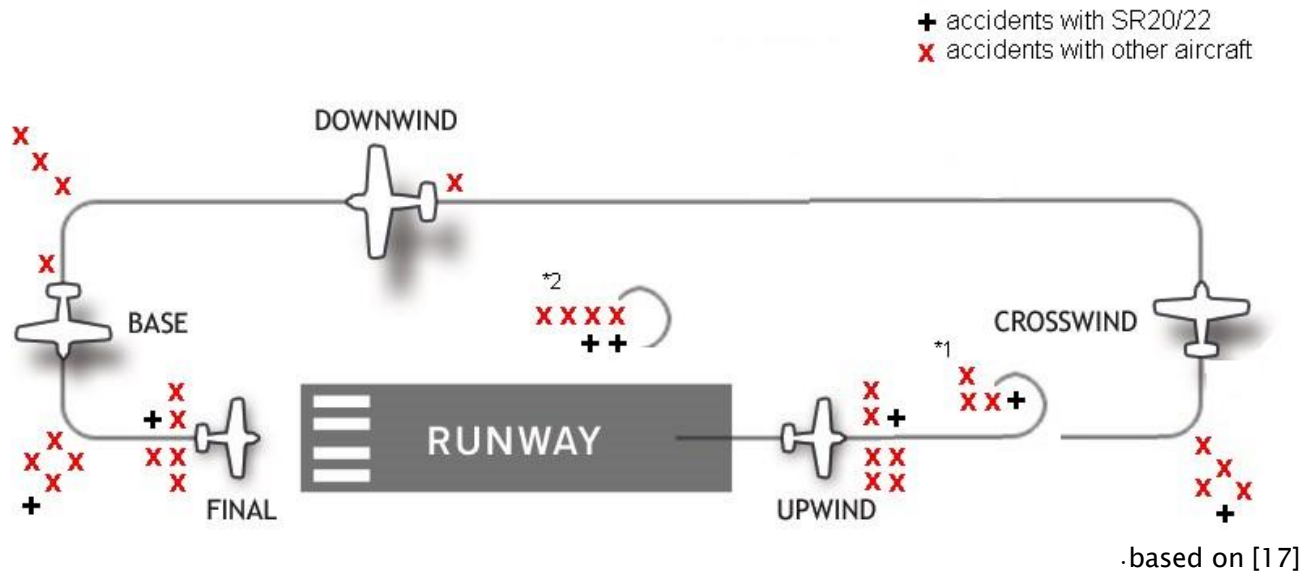

Accident reports:

- No principal difference in sequence of events
- Hints on:
 - high / suddenly induced bank angles
 - unusually steep pull up



Stalling Behaviour

- CS-23.2150 Stall characteristics, stall warning, and spins
 - (a) The aeroplane must have controllable stall characteristics in straight flight, turning flight, and accelerated turning flight with a clear and distinctive stall warning that provides sufficient margin to prevent inadvertent stalling. A stall warning that is mutable for aerobatic flight phases is acceptable.
 - (b) Single-engine aeroplanes, not certified for aerobatics, must not have a tendency to hazardously depart from controlled flight inadvertently.



Stalling Behaviour

- (c) Level -1 and -2 multi-engine aeroplanes, not certified for aerobatics, must not have a tendency to hazardously depart controlled flight inadvertently from thrust asymmetry after a critical loss of thrust.
- (d) Aeroplanes certified for aerobatics that include spins must have controllable stall characteristics and the ability to recover within one and one-half additional turns after initiation of the first control action from any point in a spin, not exceeding six turns or any greater number of turns for which certification is requested, while remaining within the operating limitations of the aeroplane.
- (e) Aeroplanes intended for aerobatics have the ability to recover from any approved manoeuvre, without exceeding limitations or exhibiting unsafe characteristics



New Stalling Criteria

Currently still being developed in the ASTM Standard

Introduced the “Departure Aversion” concept in 2016 as a means to respond to new FAA/EASA requirements for “...new rules for stall characteristics and stall warnings that would result in airplane designs more resistant to inadvertently departing controlled flight”

- Intent is to move from a prescriptive set of equipment and maneuvers (purely “pass/fail”) to an approach that allows a portfolio of possibilities that reach some specified threshold (“point value”)



New Stalling Criteria cont'd

Defines a “points” threshold that must be met, through a combination of:

- Stall warning
- Flight characteristics
- “Safety-enhancing features,” including but not limited to:
 - Enhanced indication of aircraft state data
 - Active control feedback
 - “Last-ditch” safety systems



Crashworthiness

➤ Crashworthiness (reduced specific items, now open for other ideas)

➤ CS-23.2270 Emergency Conditions

(a) The aeroplane, even when damaged in an emergency landing, must protect each occupant against injury that would preclude egress when:

(1) Properly using safety equipment and features provided for in the design;

(2) The occupant experiences ultimate static inertia loads likely to occur in an emergency landing; and

(3) Items of mass, including engines or auxiliary power units (APUs), within or aft of the cabin, that could injure an occupant, experience ultimate static inertia loads likely to occur in an emergency landing.

(b) The emergency landing conditions specified in CS 23.2270(a) must:

(1) Include dynamic conditions that are likely to occur in an emergency landing; and

(2) Not exceed established human injury criteria for human tolerance due to restraint or contact with objects in the aeroplane.

(c) The aeroplane must provide protection for all occupants, accounting for likely flight, ground, and emergency landing conditions.

(d) Each occupant protection system must perform its intended function and not create a hazard that could cause a secondary injury to an occupant. The occupant protection system must not prevent occupant egress or interfere with the operation of the aeroplane when not in use.

What's Not Different?

Part 23 ACs –

- Remain in effect except for the areas of change in previous slide
- Will need to use the cross reference table for section number alignment
- Long term plan is to incorporate into F-44 documents like the old Civil Airworthiness Manuals for CAR 3



A Detailed Review



23.2000 Applicability and Definitions

§ 23.2000 Applicability and definitions.

(a) This part prescribes airworthiness standards for the issuance of type certificates, and changes to those certificates, for airplanes in the normal category.

(b) For the purposes of this part, the following definition applies:

Continued safe flight and landing means an airplane is capable of continued controlled flight and landing, possibly using emergency procedures, without requiring exceptional pilot skill or strength. Upon landing, some airplane damage may occur as a result of a failure condition.

23.2005 Certification of Normal Category Airplanes.

(a) Certification in the normal category applies to airplanes with a passenger-seating configuration of 19 or less and a maximum certificated takeoff weight of 19,000 pounds or less.

(b) Airplane certification levels are:

(1) Level 1 – for airplanes with a maximum seating configuration of 0 to 1 passengers.

(2) Level 2 – for airplanes with a maximum seating configuration of 2 to 6 passengers.

(3) Level 3 – for airplanes with a maximum seating configuration of 7 to 9 passengers.

(4) Level 4 – for airplanes with a maximum seating configuration of 10 to 19 passengers.

23.2005 Certification of Normal Category Airplanes.

(c) Airplane performance levels are:

- (1) Low speed – for airplanes with a V_{NO} and $V_{MO} \leq 250$ Knots Calibrated Airspeed (KCAS) and a $M_{MO} \leq 0.6$.
- (2) High speed – for airplanes with a V_{NO} or $V_{MO} > 250$ KCAS or a $M_{MO} > 0.6$.

(d) Airplanes not certified for aerobatics may be used to perform any maneuver incident to normal flying, including—

(1) Stalls (except whip stalls); and

(2) Lazy eights, chandelles, and steep turns, in which the angle of bank is not more than 60 degrees.

(e) Airplanes certified for aerobatics may be used to perform maneuvers without limitations, other than those limitations established under subpart G of this part.

23.2010 Accepted Means of Compliance

- (a) An **applicant must comply with this part using a means of compliance**, which may include consensus standards, accepted by the Administrator.
- (b) An applicant requesting acceptance of a means of compliance must provide the means of compliance to the FAA in a form and manner acceptable to the Administrator.



U.S. Department
of Transportation
**Federal Aviation
Administration**

Advisory Circular

Subject: FAA Accepted Means of Compliance
Process for 14 CFR Part 23

Date:

AC No: 23.2010

Initiated by: ACE-100

Draft compliance checklist using ASTM as MOC

Requirement	Sub-para	Compliance ref	Compliance ref. section	MOC	Method	Compliance Document	Doc. Status	Remarks / Comments / Statement	LOI
23.2200 Structural design envelope									
		F3116-15	4.4 Flight envelope 4.5 Limit maneuvering load factors 4.6 Gust load factors	2	Gust load factors are calculated using formulas in F3116 (4.6.3)	LA-EASA-000014 Loads Flight Envelope		Requirements for aerobatics, level 4, canard and tandem wing aeroplanes are not considered.	
	(a)(1)	F3116-15	5.1 Design Airspeeds	2	Vd is calculated as 1.4Vc	LA-EASA-000010 Flight loads			
	(a)(2)	F3174-15	4.2 Airspeed limitations 4.3 Operating Maneuvering Speed 4.4 Flap Extended Speed	1,2	Calculation based on the design speeds derived using F3116-15	DE-EASA-000001 Main datasheet			
	(b)			0				Flight load conditions expected in service are considered by showing compliance to 23.2225	
	(c)	F3116-15	4.2 Flight loads – General	2	Variation from design minimum to maximum weight will be considered in loads determination	LA-EASA-000014 Loads Flight Envelope Rev. 0			

What Else is Different?

End of Program

Documenting TCDS is somewhat different –

- List Airworthiness Level and Performance
- Notes may include important required equipment where matrix approach is used



What Else is Different?

4. Add other miscellaneous notes, if the FAA does not offer necessary information elsewhere.
5. ACOs may develop a note to require a modifier to coordinate with them before making a proposed change, for example, cockpit installations or integrated avionics approvals. The ACO must coordinate this with the accountable directorate staff.
6. For Part 23 airplanes using Amendment 63 or later, include important information that may not be obvious in the certification basis such as:
 - Ballistic parachutes systems not for credit verses for credit
 - Crashworthiness features that were required verses not required
 - Low speed characteristics – matrix features required
 - That the applicant used a proprietary means of compliance
 - Gust or Load alleviation for credit

21.101 Discussion

- STCs / Modifications do not require going to the latest amendment
 - Does not contribute materially to the level of safety
 - Impractical
- For larger Part 23 airplanes, staying at the lower amendment level may make more sense for all parties
- Applicants may want the latest amendment for select areas if they see benefits – already seeing examples of this



-
- Unusual aircraft that resemble recreational drones, UAS aircraft, and NASA's distributed thrust aircraft can benefit from using top level requirements. Under both 21.17 or Part 23
 - This allows the authorities and applicant to make numerous changes to the MOC during the development stages without re-noticing the requirements under 21.17 or re-publishing special conditions / ELOS / or exemptions under Part 23.



Benefits of Performance-Based Rules

Top level performance-based requirement

12. Stability.

(a) In all flight phases and modes the aircraft must—

- (1) Have static longitudinal, lateral, and directional stability in normal operations;
- (2) Have dynamic short period and Dutch roll stability in normal operations; and
- (3) Provide stable control force or displacement feedback throughout the operating envelope.

(b) No airplane may exhibit any divergent longitudinal stability characteristic so unstable as to increase the pilot's workload or otherwise endanger the airplane and its occupants.

Means of Compliance

12.1 Stability: general – forward flight mode (23.171)

The aircraft must be longitudinally, directionally, and laterally stable. In addition, the aircraft must show suitable stability and control “feel” (static stability) in any condition normally encountered in service, if flight tests show it is necessary for safe operation.

12.2 Stability: general – vertical flight mode (27.171)

The aircraft must be able to be flown, without undue pilot fatigue or strain, in any normal maneuver for a period of time as long as that expected in normal operation. At least three landings and takeoffs must be made during this demonstration.

12.3 Static longitudinal stability – forward flight mode (23.173)

Under the conditions specified in PZ23.175 and with the aircraft trimmed as indicated, the characteristics of the pitch control forces and the friction within the control system must be as follows:

(a) A pull must be required to obtain and maintain speeds below the specified trim speed and a push required to obtain and maintain speeds above the specified trim speed. This must be shown at any speed that can be obtained, except that speeds requiring a control force in excess of 40 pounds or speeds above the maximum allowable speed or below the minimum speed for steady unstalled flight, need not be considered.

(b) The aircraft must return to within the tolerances specified for (a normal category airplane) when the control force is slowly released at any speed within the speed range specified in paragraph (a) of this section. The applicable tolerances are—

(1) The airspeed must return to within plus or minus 10 percent of the original trim airspeed.

(c) The stick force or displacement must vary with speed so that any substantial speed change results in a stick force or stick displacement clearly perceptible to the pilot.

12.8 Dynamic stability. (23.181)

(a) Any short period oscillation not including combined lateral-directional oscillations occurring between the stalling speed and the maximum allowable speed appropriate to the configuration of the airplane must be heavily damped with the primary controls—

(1) Free; and

(2) In a fixed position.

(b) Any combined lateral-directional oscillations (Dutch roll) occurring between the stalling speed and the maximum allowable speed (VFE, VLE, VNO, VFC/MFC) appropriate to the configuration of the airplane with the primary controls in both free and fixed position, must be damped to 1/10 amplitude in:

(1) Seven (7) cycles below 18,000 feet and

(2) Thirteen (13) cycles from 18,000 feet to the certified maximum altitude.

(c) If it is determined that the function of a stability augmentation system, reference PZ23.672, is needed to meet the flight characteristic requirements of this part, the primary control requirements of paragraphs (a)(2) and (b)(2) of this section are not applicable to the tests needed to verify the acceptability of that system.

Should be transparent in a FBW system?



Means of Compliance

to 14 CFR Part 23
Airworthiness Standards
for Normal Category
Airplanes

Presented to: GAMA Small Airplane
Certification Workshop

By: Steve Thompson

FAA Small Airplane Standards Staff

Date: April 27, 2017

Objective:

To gain a clear understanding of:

1. how consensus standards and other means of compliance complement performance-based rules,
2. what Part 23 Amdt 64 requires of an applicant in showing compliance to small airplane certification requirements, and
3. how to meet these new “means of compliance” requirements.

Flight Plan

1. Performance-Based Rules
2. Means of Compliance (MOC)
3. Standards as MOC
4. ASTM International
5. Standards Development & FAA Acceptance
6. Using MOC in Certification Projects
7. Delegation
8. Global Initiatives



Flight Plan

1. Performance-Based Rules
2. Means of Compliance (MOC)
3. Standards as MOC
4. ASTM International
5. Standards Development & FAA Acceptance
6. Using MOC in Certification Projects
7. Delegation
8. Global Initiatives



Prescriptive vs. Performance-Based Rules

Prescriptive Regulatory System	Performance-Based Regulatory System
Establishes specific technical requirements that must be met by applicants and approval holders	Establishes <i>outcomes</i> that must be achieved; allows flexibility in how the applicant or approval holder achieves those outcomes
<i>Example:</i> Emergency exits must be movable windows, panels, canopies, or external doors...that provide a clear and unobstructed opening large enough to admit a 19-by-26-inch ellipse.	<i>Example:</i> The airplane must be designed to facilitate rapid and safe evacuation in conditions likely to occur following an emergency landing.

Performance-Based Regulations

Pros and Cons

Pros	Cons
<p data-bbox="131 368 865 491">Greater agility in accommodating innovation and new technologies</p> <p data-bbox="200 494 649 525"><i>Primary Goal of Part 23, Amdt 64</i></p> <p data-bbox="131 576 911 676">Stronger focus on achieving the desired safety performance</p> <p data-bbox="131 811 772 856">Improved understanding of risks</p> <p data-bbox="131 991 834 1090">Potential for stronger safety culture within regulator and industry</p>	<p data-bbox="987 374 1657 474">Defining requirements in terms of performance can be challenging.</p> <p data-bbox="987 482 1611 514"><i>Accomplished by issuance of Part 23, Amdt 64</i></p>  <p data-bbox="987 576 1773 676">Defining what compliance looks like can be difficult</p> <p data-bbox="1151 691 1588 759"><i>Development and Acceptance of Means of Compliance (MOC)</i></p> <p data-bbox="987 811 1692 911">Compliance planning requires more effort</p> <p data-bbox="1089 931 1653 962"><i>Appropriate Application of Accepted MOC</i></p>

*Reference: > Presentation by Dr. M. Sam Mannan, Texas A&M, 2012 Forum on Performance-Based Regulatory Models
 > EASA, as summarized by European Cockpit Association



Flight Plan

1. Performance-Based Rules
2. Means of Compliance (MOC)
3. Standards as MOC
4. ASTM International
5. Standards Development & FAA Acceptance
6. Using MOC in Certification Projects
7. Delegation
8. Global Initiatives



Accepted Means of Compliance

14 CFR Part 23, Amdt 64

§ 23.2010 Accepted means of compliance.

(a) An applicant must comply with this part using a means of compliance, which may include consensus standards, accepted by the Administrator.

(b) An applicant requesting acceptance of a means of compliance must provide the means of compliance to the FAA in a form and manner acceptable to the Administrator.

Key Takeaways from §23.2010

- §23.2010(a)
 - Applicants must use MOC that have been accepted by the Administrator for showing compliance to part 23
 - An applicant's accepted MOC *may* include consensus standards, but are not required to include consensus standards
 - An applicant may choose not to use any consensus standards, or a combination of accepted consensus standards and other accepted MOC
- §23.2010(b)
 - Applicants may request acceptance of new MOC that have not previously been accepted for general application in part 23 certification projects (more on this later)

How Does This Change Our Work?

Today Part 23 Amdt 63

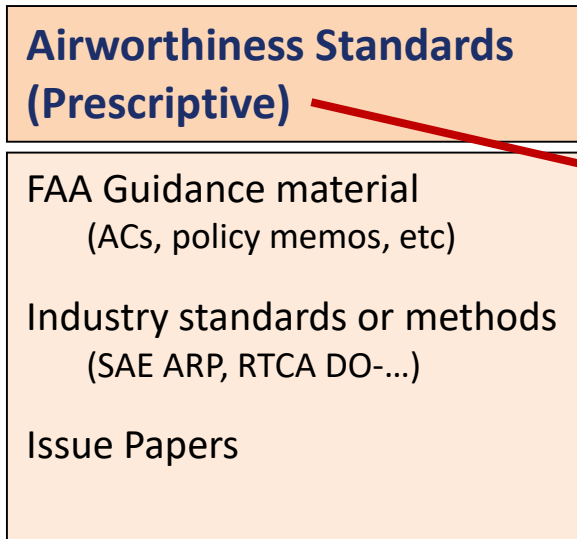

August 2017 Part 23 Amdt 64

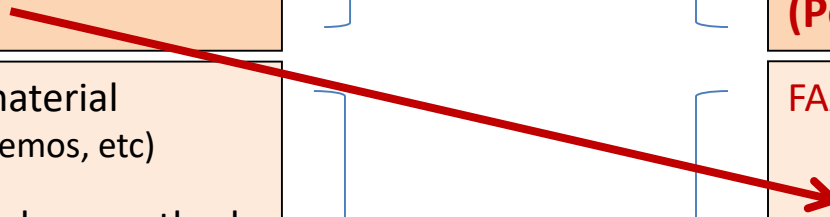
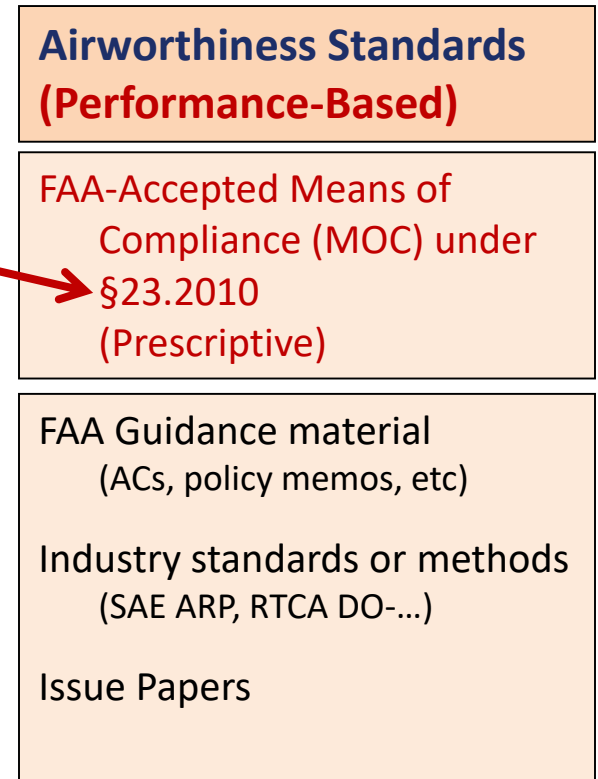

Flight Plan

1. Performance-Based Rules
2. Means of Compliance (MOC)
3. Standards as MOC
4. ASTM International
5. Standards Development & FAA Acceptance
6. Using MOC in Certification Projects
7. Delegation
8. Global Initiatives



We've Used Industry Standards for Decades

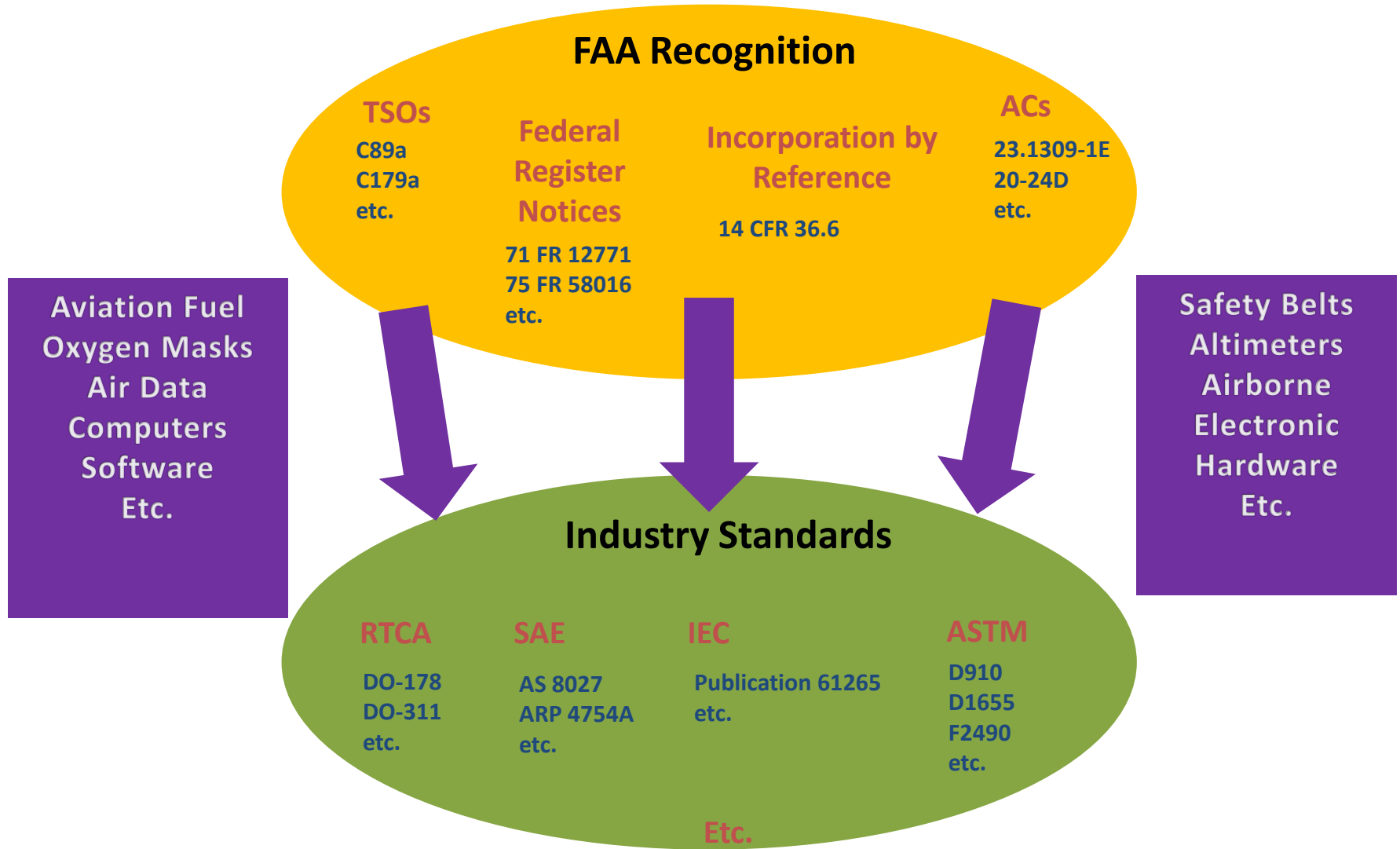

Consensus Standards

Not all industry standards are consensus standards

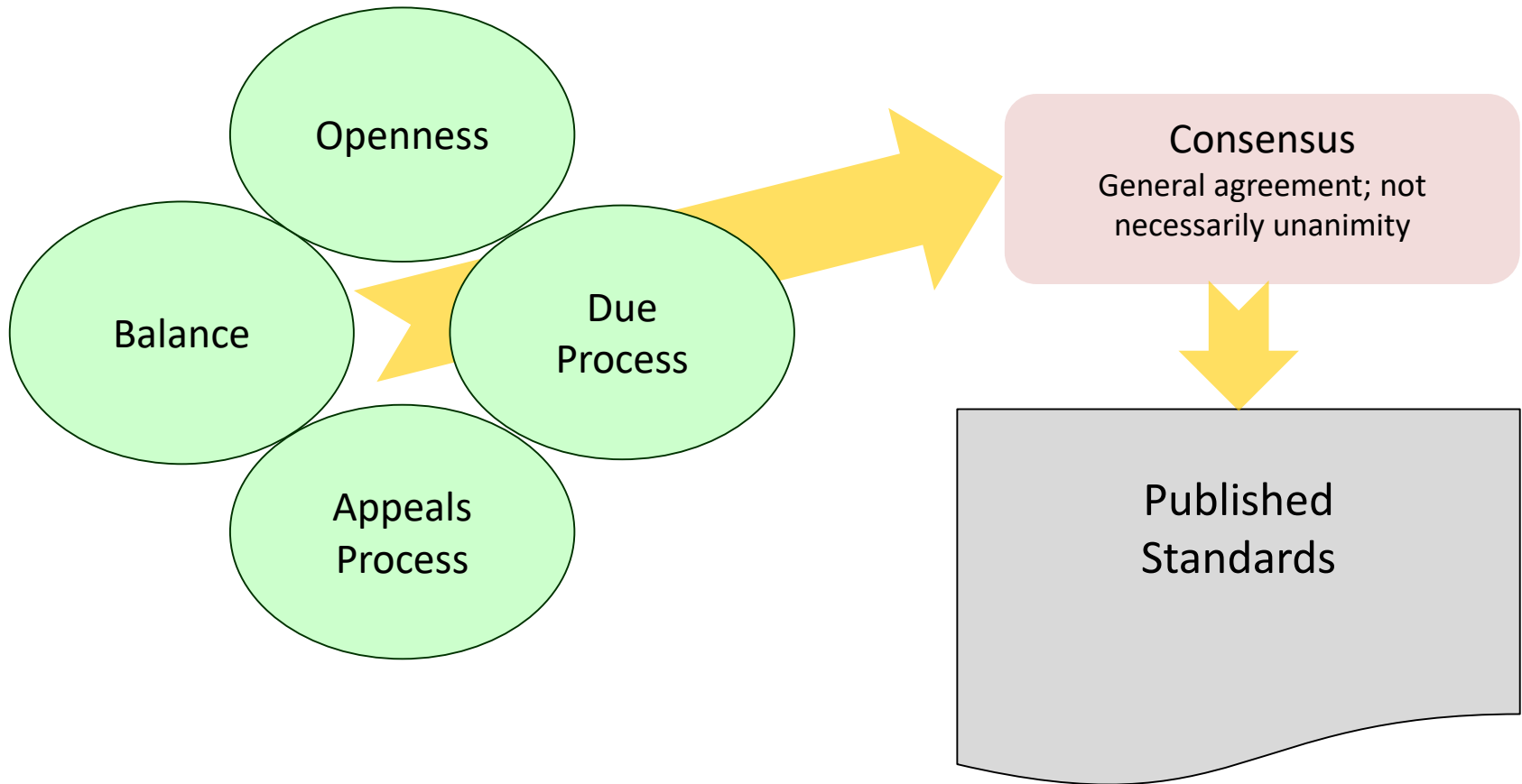

Ref. OMB Circular A-119, Revised January 27, 2016

Use of Consensus Standards

- Public Law 104-113: National Technology Transfer and Advancement Act of 1995
 - Calls on Federal agencies to use voluntary consensus standards as means of carrying out policy objectives
- Small Airplane Revitalization Act of 2013
 - One objective is the use of consensus standards accepted by the FAA to meet the safety objectives of part 23

Flight Plan

1. Performance-Based Rules
2. Means of Compliance (MOC)
3. Standards as MOC
4. ASTM International
5. Standards Development & FAA Acceptance
6. Using MOC in Certification Projects
7. Delegation
8. Global Initiatives



ASTM International

- Organization chosen by industry to develop standards for use with part 23, CS-23, and other CAA rules
- Meets Government criteria for consensus standards bodies through:
 - Collaboration and consensus of those affected
 - Openness
 - Balance among competing interests
 - Transparency
 - Due process

Clearing Up Common Misconceptions

- Industry groups -- *not* FAA -- identified ASTM as the appropriate organization to initiate development of consensus standards
- ASTM does *not* have personnel on staff writing standards for part 23 use (or any other industry).
- Knowledgeable and experienced volunteers from industry, government, academia, etc. develop technical standards
- ASTM does *not* establish part 23 certification requirements
- ASTM publishing a standard does *not* mean that standard is accepted for use in showing compliance to part 23
- Part 23 framework \neq light-sport aircraft framework

ASTM Committee F44 on GA Aircraft

- 250 members / 9 subcommittees
- Multinational effort
 - 22 countries represented in membership
 - FAA and Civil Aviation Authorities from Europe, Canada, Brazil, China, New Zealand, and Australia
 - Global producers, including GAMA, Textron, Diamond, Flight Design, Mooney, Piper, Pipistrel, Garmin, Avidyne, many more
 - General aviation users, academia, and other interests, including AOPA, NASA, AEA, Wichita State, Embry Riddle, etc.
- Total of 29 standards needed initially
 - All are now published
 - **None have been accepted by FAA under §23.2010 for use as means of compliance with part 23 (in review)**

ASTM F44 Sub-Committees

- F44.10 General
- F44.20 Flight
- F44.30 Structures
- F44.40 Powerplant
- F44.50 Systems and Equipment
- F44.90 Executive
- F44.91 Terminology
- F44.92 Regulatory Liaisons
- F44.93 Industry Liaison
- There are also Working Groups within sub-committees

ASTM F44 Published Standards

- F44 used the prescriptive requirements of Part 23 Amdt 62, CS-23, and CS-VLA as the foundation for initial standards
- These baseline standards are the building blocks for development of additional MOC and a clear path to compliance for future technologies
- **General Topics**
 - F3060-16a Standard Terminology for Aircraft
 - F3117-15 Standard Specification for Crew Interface in Aircraft
 - F3120/F3120M-15 Standard Specification for Ice Protection for General Aviation Aircraft

ASTM F44 Published Standards

- Flight
 - F3082/F3082M-16 Standard Specification for Flight for General Aviation Aeroplanes
 - F3173/F3173M-15 Standard Specification for Handling Characteristics of Aeroplanes
 - F3174/F3174M-15 Standard Specification for Establishing Operating Limitations and Information for Aeroplanes
 - F3179/F3179M-16 Standard Specification for Performance of Aeroplanes
 - F3180/F3180M-16 Standard Specification for Low-Speed Flight Characteristics of Aeroplanes

ASTM F44 Published Standards

- Structures
 - F3083/F3083M-16 Standard Specification for Emergency Conditions, Occupant Safety and Accommodations
 - F3093/F3093M-15 Standard Specification for Aeroelasticity Requirements
 - F3114-15 Standard Specification for Structures
 - F3115/F3115M-15 Standard Specification for Structural Durability for Small Airplanes
 - F3116/F3116M-15 Standard Specification for Design Loads and Conditions

ASTM F44 Published Standards

- Powerplant
 - F3062/F3062M-16 Standard Specification for Installation of Powerplant Systems
 - F3063/F3063M-16a Standard Specification for Design and Integration of Fuel/Energy Storage and Delivery System Installations for Aeroplanes
 - F3064/F3064M-15 Standard Specification for Control, Operational Characteristics and Installation of Instruments and Sensors of Propulsion Systems
 - F3065/F3065M-15 Standard Specification for Installation and Integration of Propeller Systems
 - F3066/F3066M-15 Standard Specification for Powerplant Systems Specific Hazard Mitigation

ASTM F44 Published Standards

- Systems and Equipment
 - F3061/F3061M-17 Standard Specification for Systems and Equipment in Small Aircraft
 - F3227/F3227M-17 Standard Specification for Environmental Systems in Small Aircraft
 - F3228-17 Standard Specification for Flight Data and Voice Recording in Small Aircraft
 - F3229/F3229M-17 Standard Practice for Static Pressure System Tests in Small Aircraft
 - F3230-17 Standard Practice for Safety Assessment of Systems and Equipment in Small Aircraft
 - F3231/F3231M-17 Standard Specification for Electrical Systems in Small Aircraft

ASTM F44 Published Standards

- Systems and Equipment (cont'd)
 - F3232/F3232M-17 Standard Specification for Flight Controls in Small Aircraft
 - F3233/F3233M-17 Standard Specification for Instrumentation in Small Aircraft
 - F3234/F3234M-17 Standard Specification for Exterior Lighting in Small Aircraft
 - F3235-17 Standard Specification for Electrical Storage Batteries in Small Aircraft
 - F3236-17 Standard Specification for High Intensity Radiated Field (HIRF) Protection in Small Aircraft

Top Level Specification (TLS)

- F44 is developing a Top Level Specification to:
 - Organize the suite of F44 standards
 - Provide a “bridge” between F44 standards content and CAA regulatory requirements
 - Facilitate global CAA harmonization and acceptance of standards
- TLS is not yet finalized or published
- Goal is for coordinated CAA acceptance of TLS

A formal acceptance may specify exceptions or deviations to the published standard(s), but CAAs are striving to minimize these through F44 collaboration

Top Level Specification Concept

5. Means of Compliance – Flight

5.1 Weight/Mass and Centre of Gravity (B-23.2100) (B-23.2100)

5.1.1 F3082/F3082M-16 Standard Specification for Flight for General Aviation Aeroplanes

5.2 Performance Data (B-23.2105) (B-23.2105)

5.2.1 F3179/F3179-16 Standard Specification for Performance of Aeroplane

5.3 Stall Speed (B-23.2110) (B-23.2110)

5.3.1 F3180/F3180M-16 Standard Specification for Low-Speed Flight Characteristics of Aeroplanes

5.4 Takeoff Performance (B-23.2115) (B-23.2115)

5.4.1 F3179/F3179M-16 Standard Specification for Performance of Aeroplanes

5.5 Climb Requirements (B-23.2120) (B-23.2120)

5.5.1 F3179/F3179M-16 Standard Specification for Performance of Aeroplanes

5.6 Climb Information (B-23.2125) (B-23.2125)

5.6.1 F3179/F3179M-16 Standard Specification for Performance of Aeroplanes

5.7 Landing (B-21.2130) (B-23.2130)

5.7.1 F3179/F3179M-16 Standard Specification for Performance of Aeroplanes



Flight Plan

1. Performance-Based Rules
2. Means of Compliance (MOC)
3. Standards as MOC
4. ASTM International
5. Standards Development & FAA Acceptance
6. Using MOC in Certification Projects
7. Delegation
8. Global Initiatives



Applicants

SDO

FAA

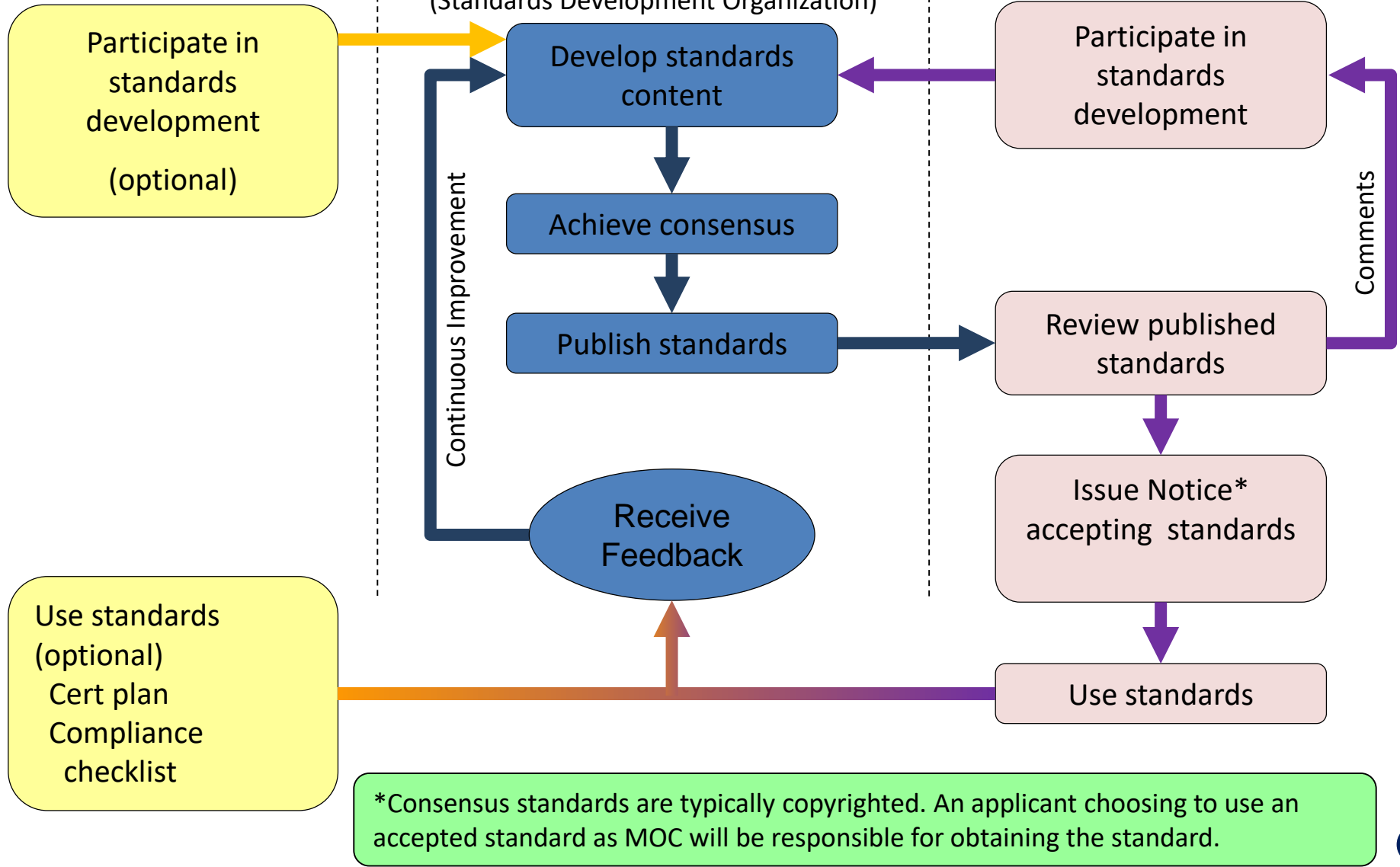

Flight Plan

1. Performance-Based Rules
2. Means of Compliance (MOC)
3. Standards as MOC
4. ASTM International
5. Standards Development & FAA Acceptance
6. Using MOC in Certification Projects
7. Delegation
8. Global Initiatives



How to Comply with §23.2010

As early as possible, identify the intended MOC to be used

- Provide as much information as possible about intended MOC during initial familiarization meetings with the Aircraft Certification Office
- Identify intended MOC in the certification plan / compliance checklist
 - Emphasize any proposed new MOC that have not previously been accepted, and include rationale for how the proposed means demonstrate compliance with part 23
- Obtaining FAA acceptance of MOC at the beginning of the certification process is not required, but doing so will minimize program risk
 - Scope and applicability of previously accepted MOC can be verified
 - If new MOC are proposed, additional time and effort are likely for FAA review. Applicants should take this into account in their program plans and project schedules.
- When new technology prompts new MOC, finalizing the MOC in the early stages of the certification project may not be possible.

Accepted MOC

- What MOC are currently accepted for Part 23, Amdt 64?
 - The prescriptive requirements of Part 23, Amdt 63 with associated FAA policy statement, **except for requirements pertaining to loss of control and icing**
 - Policy statement will address known errors in Amdt 63, ELOS findings, and special conditions
- How will I know when additional MOC have been accepted for general application in part 23?
 - Through a Notice published in the *Federal Register*
 - Through an update to a summary list of accepted standards to be published on the FAA Internet
- How will I know what alternative MOC have been accepted for use on a project-specific basis?
 - This information will not generally be available. The FAA protects applicants' proprietary data and does not provide alternative MOC provided by applicants to third parties unless specifically authorized by the applicant.

Acceptance of New MOC

- How do I get new MOC accepted by the Administrator?
 - For General Application: Propose a new work item to ASTM Committee F44 or other standards development organization
 - For Project-Specific Application: Propose the MOC to your Aircraft Certification Office. Your proposal will be considered using the process identified in Advisory Circular (AC) 23.2010-1. An issue paper may be necessary for coordination with FAA technical specialists and other personnel.
 - To be accepted, any MOC must meet the safety intent of the regulations and maintain the level of safety established in part 23

§21.101 Designation of Applicable Regulations

- What effects does §21.101 ('changed product rule') have on accepted means of compliance?
 - No direct effects; 21.101 applies to applicable regulations, not means of compliance with those regulations
 - Indirectly, the certification basis established under §21.101 will affect which means of compliance are applicable and accepted
 - Where 21.101 would allow compliance to be shown with an earlier amendment, applicants may choose to voluntarily use the more flexible performance-based standards of Amdt. 64 and associated accepted MOC.
 - Supplemental Type Certificate (STC) and Amended Type Certificate (ATC) applicants will continue to be required to demonstrate that their changes, and areas affected by their changes, comply with the applicable *regulations* (regardless of MOC used for original certification).

The FAA and its designees make compliance findings to 14 CFR part 23 airworthiness standards (regulations), not to industry standards or other forms of MOC.



Flight Plan

1. Performance-Based Rules
2. Means of Compliance (MOC)
3. Standards as MOC
4. ASTM International
5. Standards Development & FAA Acceptance
6. Using MOC in Certification Projects
7. Delegation
8. Global Initiatives



Delegation and the new Part 23

- Not much will be changing for designees
- The certification plan will identify the regulations and the designee (if any) who may find compliance to them (just like today)
- Form 8110-3 or 8100-9 will be filled out almost exactly the same way as for previous amendments of part 23
- The exception being the FAA will expect that the MOC that was used to demonstrate compliance will be listed in the title block under list of data (block 7 on the 8110-3 form)

Delegation and the new Part 23

- That's pretty much it, as a DER or UM you will still find compliance to regulations as delegated by the FAA
- You'll need to document the MOC used on either the 8110-3 or 8100-9 form as appropriate
- If needed, change your delegation documentation to remove specific regulation references



Flight Plan

1. Performance-Based Rules
2. Means of Compliance (MOC)
3. Standards as MOC
4. ASTM International
5. Standards Development & FAA Acceptance
6. Using MOC in Certification Projects
7. Delegation
8. Global Initiatives



EASA is Also Moving to a Performance-Based Approach

- EASA issued CS-23 Amdt 5 in March 2017, with an effective date of August 15, 2017
- While there are some differences, EASA and FAA's rules are substantially harmonized
- Like the FAA's rule, EASA also requires use of accepted means of compliance:

CS 23.2010 Accepted means of compliance

- (a) An applicant must comply with this CS using an acceptable means of compliance (AMC) issued by EASA, or another means of compliance which may include consensus standards, when specifically accepted by EASA.
- (b) An applicant requesting EASA to accept a means of compliance must provide the means of compliance to EASA in an acceptable form and manner.

Other CAAs and Global Industry

- Several additional civil aviation authorities have also been active in the development of consensus standards and are considering how to move forward with a performance-based approach
- The global industry is active in developing consensus standards for use with FAA, EASA, and other CAA rules
- A shared goal is for CAAs globally to be able to accept the same MOC as much as possible, even when regulatory language is not identical

CAA Harmonization

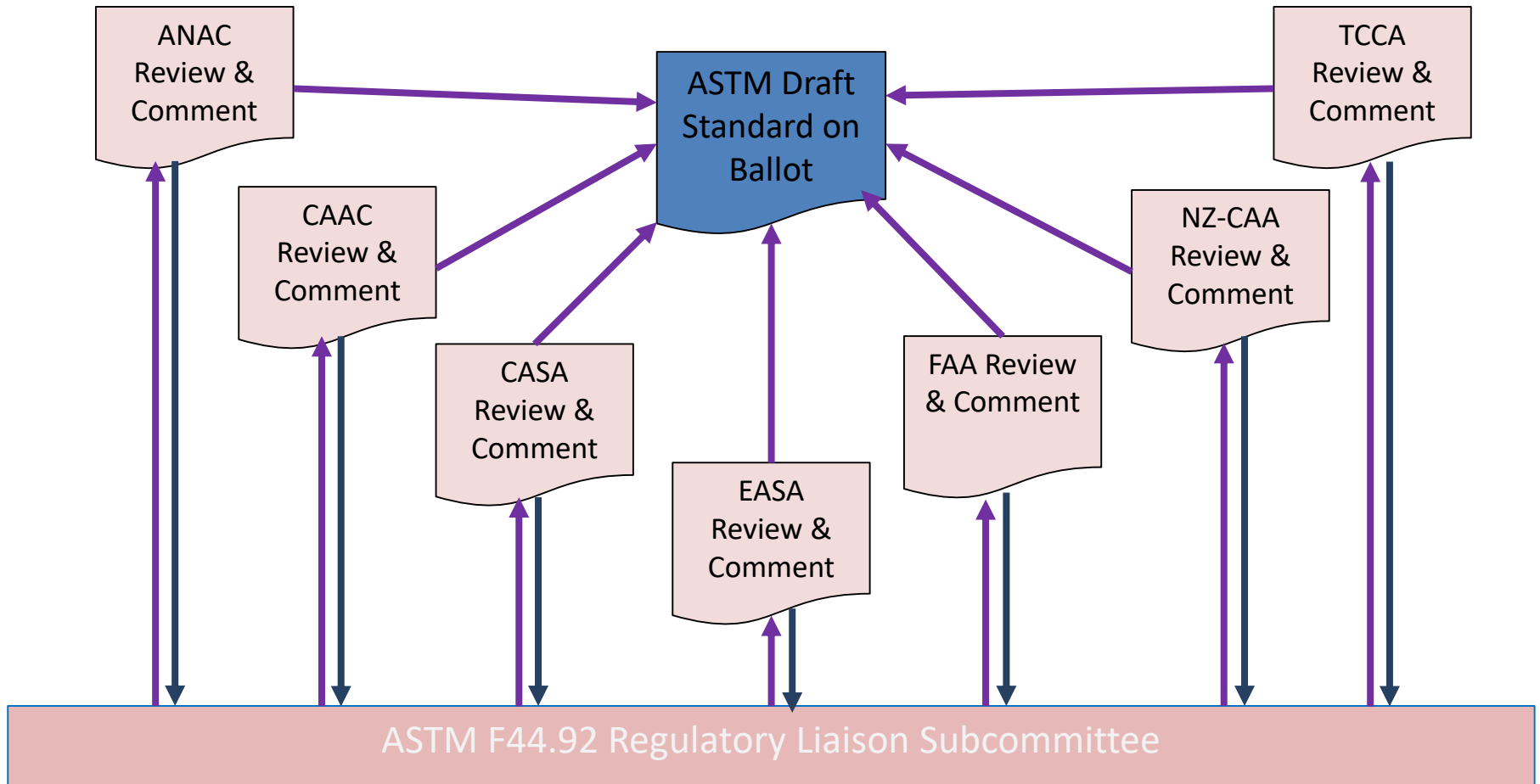

Flight Plan

1. Performance-Based Rules
 2. Means of Compliance (MOC)
 3. Standards as MOC
 4. ASTM International
 5. Standards Development & FAA Acceptance
 6. Using MOC in Certification Projects
 7. Delegation
 8. Global Initiatives
- <<< Final Approach >>>

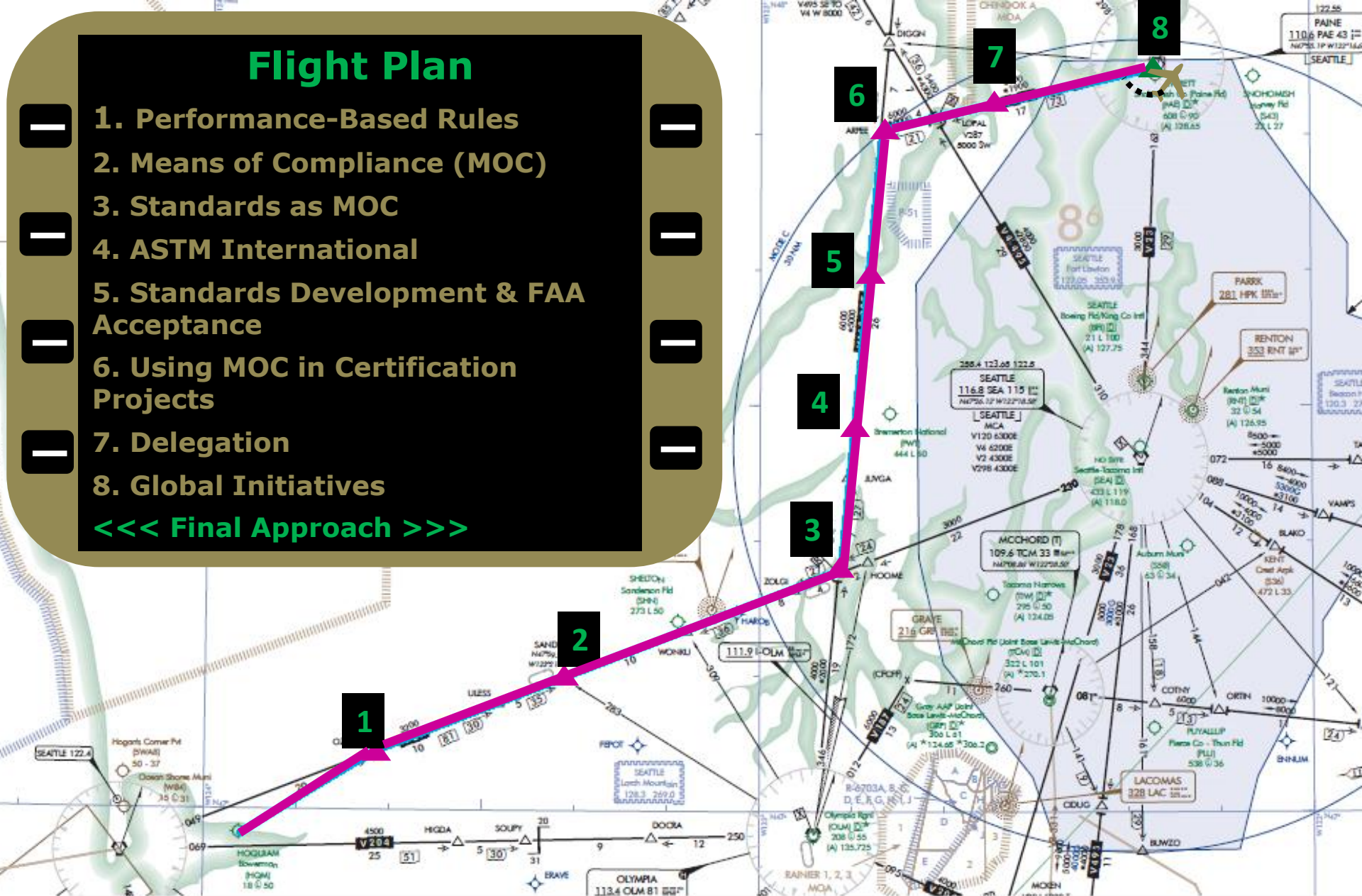

Managing the Change

The FAA is striving to ensure both internal and external stakeholders understand the new rule's requirements for means of compliance

- Conducting detailed workshops at each ACO
- Developing computer-based training for ACO engineers
- Issuing AC 23.2010-1
- Incorporating information into DER and ODA UM training
- Coordinating with other CAAs
- Participating in industry workshops

Recap

We covered:

1. How consensus standards and other means of compliance complement performance-based rules
2. What Part 23 Amdt 64 requires of an applicant in showing compliance to small airplane certification requirements
3. How to meet these new “means of compliance” requirements

Additional Questions?

Online Resources

- [Part 23 Aviation Rulemaking Committee \(ARC\) Report and Related Files](#)
- [Small Airplane Revitalization Act](#)
- [National Technology Transfer and Advancement Act of 1995](#)
- [Office of Management and Budget \(OMB\) Circular A-119](#)
- [Part 23 Notice of Proposed Rulemaking \(March 2016\)](#)
- [Part 23 Amendment 64 Final Rule \(December 2016\)](#)
- [AC 23.2010-1: FAA Accepted Means of Compliance Process for 14 CFR Part 23](#)
- [ASTM International Committee F44 Home Page](#)
- [Federal Register Home Page](#)
- [FAA Regulations, Policy, and Guidance - Small Airplanes](#)



EASA
European Aviation Safety Agency

Impact on Certification Process

CS 23 Reorganisation Workshop - Mar 2017

Pasquale Violetti
PCM General Aviation

Your safety is our mission.

An agency of the European Union 

TE.GEN.00409-001

Overview

Type Certification – Phases overview

Phase	0	I	II	III	IV
Description	Definition and agreement of the working methods	Technical familiarisation and establishment of the TC basis	Agreement of the Certification Programme and Level of Involvement	Compliance determination	Final phase
Main steps	Eligibility check; Gen. Fam. Meeting.	Kick off Meeting; Familiarisation meetings.	Review of Certification Programmes; Determination of Lol.	Verification by the EASA team of the applicant compliance demonstration	Final TBM; ESC presentation.
Conditions for closure	Application acceptance; Team nomination.	Technical familiarisation of the team completed; First issue of CRI A-01 notified to the applicant; The initial set of applicable CRIs drafted; First issue of PID.	Certification Programme acceptance; Issuance of CAI documenting the Lol and accepted by the EASA team; All CRIs issued and closed.	Completion of EASA verification activity (document review, test witnessing, audits and flight test); Preliminary list of Post TC mandatory actions available.	Final report issuance; TCDS/TCDNS issuance; TC issuance.

Application acceptance

- Application Forms remains unchanged
 - FO.00030-002 (Type Certificate or Restricted TC)
 - FO.00031-002 (Major Change or Major Repair Design)
 - FO.00033-002 (Supplemental Type Certificate)

4.3 Airworthiness Code^a	Please specify the proposed airworthiness code, e.g. CS-23 ^a
---	---

- No need to indicate selected AMC at this stage
- No impact on eligibility check, as it depends on product categorization in terms of ELA or not ELA and related DOA capability

Certification Basis

➤ What's different?

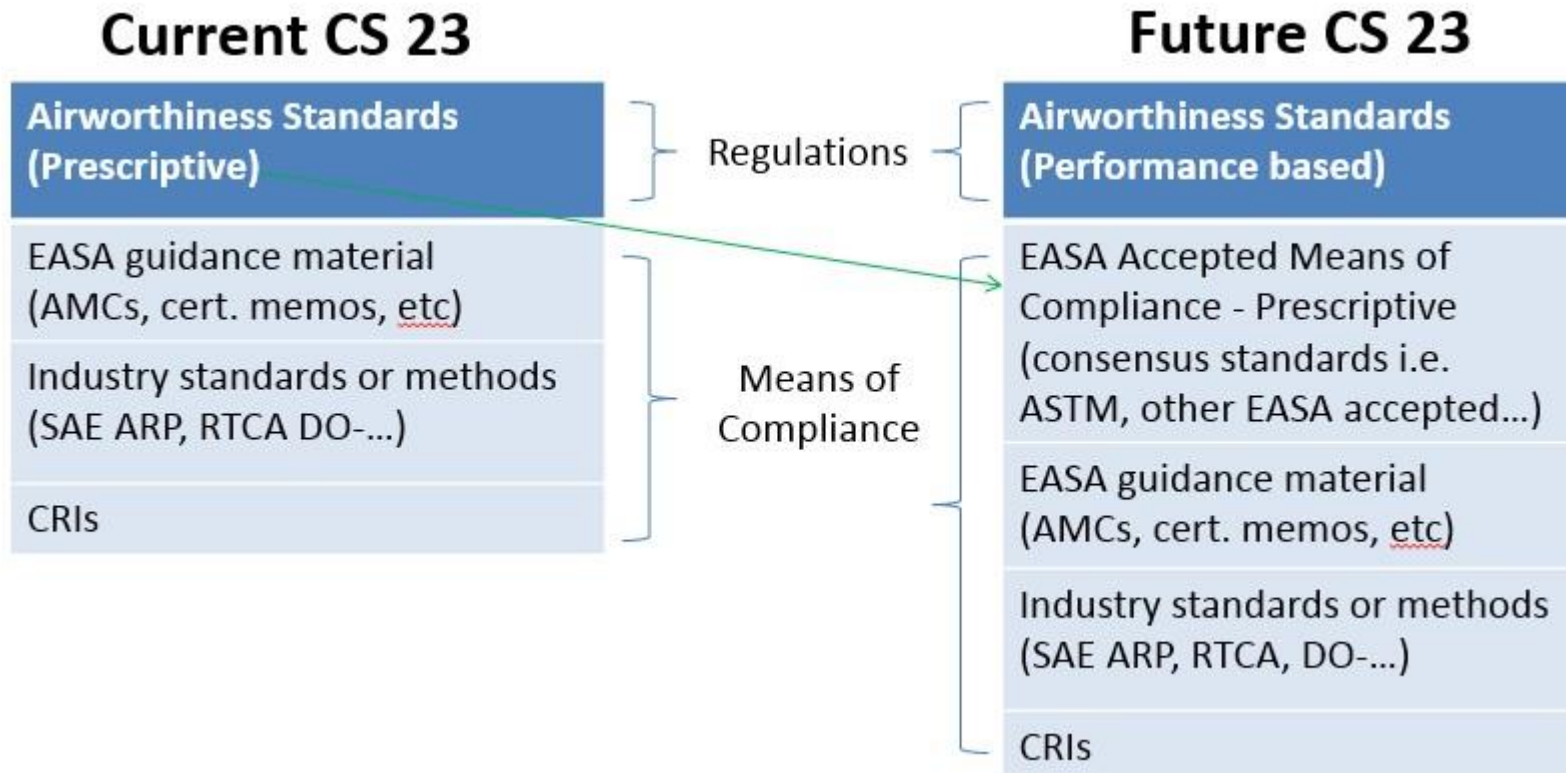

CS-23 subparts comparison

CS-23 amdt 4	CS-23 amdt 5
Subpart A – General	Subpart A – General
Subpart B - Flight	Subpart B - Flight
Subpart C – Structure	Subpart C – Structures
Subpart D – Design and Construction	Subpart D – Design and Construction
Subpart E – Powerplant	Subpart E – Powerplant
Subpart F – Equipment	Subpart F – Systems and Equipment
Subpart G – Operating Limitations and Information	Subpart G – Flight Crew Interface and Other Information

While they almost perfectly match concerning subpart segregation...forget about paragraph numbering!!

New paragraph numbering

SUBPART E — POWERPLANT
CS-23.2400 Powerplant and propulsion system installation.....
CS-23.2405 Power or thrust control systems
CS-23.2410 Powerplant and propulsion system installation hazard assessment
CS-23.2415 Powerplant and propulsion system ice protection.....
CS-23.2420 Powerplant and propulsion system fire protection
CS-23.2425 Powerplant and propulsion system operational characteristics

- The level of change (from prescriptive to performance based requirements) is so deep that keeping the old numbering system makes no sense
- EASA is working on a cross reference matrix between current and future requirements, intended to be published with the AMC

MOC List – Prescriptive requirements

- Currently, MOC are proposed against the prescriptive requirement

CS Paragraph	Title	CS requirement	Method of Compliance	N	0	1	2	3	4	5	6	7	8	9	Reference Documents <i>To be completed at later issues</i>
SUBPART E - POWERPLANT															
967 (e) 1	Fuel tank installation	So as to retain fuel when subjected to the inertia loads resulting from the ultimate static load factors prescribed in CS 23.561 (b) (2); and	Classical & FEA calculations			x									Fuel Tank Load Tests Report TR-GB1-28-10-001 Fuel Tanks Stress Calculations Report CA-GB1-28-10-001
967 (e) 2	Fuel tank installation	So as to retain fuel under conditions likely to occur when an aeroplane lands on a paved runway at a normal landing speed under each of the following conditions:		I											
967 (e) 2 (i)	Fuel tank installation	The aeroplane in a normal landing attitude and its landing gear retracted.		x											
967 (e) 2 (ii)	Fuel tank installation	The most critical landing gear leg collapsed and the other landing gear legs extended. In showing compliance with sub-paragraph (e) (2) , the tearing away of an engine mount must be considered unless all the engines are installed above the wing or on the tail or fuselage of the aeroplane.	Design review then statement in Compliance Summary.			x									Powerplant compliance summary CS-GB1-72-00-001
967 (e) 2	Fuel tank	For commuter category aeroplanes, fuel tanks within the fuselage contour must be able to resist													

- This is generally sufficient to provide comprehensive information of how compliance will be demonstrated

MOC List – New CS 23

- Proposing means of compliance against the objective rules (performance based) is too generic.

CS Par.	Title	CS requirement	MOC	Documents
23.2225 (a)(3)	Component loading conditions	The applicant must determine the loads acting upon all relevant structural components, in response to: Flight load conditions	2	LA-EASA-551001 LA-EASA-576001 . . .

NOT ACCEPTABLE

- Reference to selected ASTM standards (or other AMC) shall be provided already at this stage (certification plan or compliance check list)

CS-23.2010

CS-23.2010 Accepted means of compliance.

(a) An applicant must comply with this part using an Acceptable Means of Compliance (AMC) issued by EASA, or another means of compliance which may include consensus standards, when specifically accepted by the EASA.

(b) An applicant requesting acceptance of a means of compliance must provide the means of compliance to the Agency in an acceptable form and manner.

Acceptance of MOC

- EASA will publish an AMC to CS 23 amdt 5 with a list of Accepted Means of Compliance
 - F44 ASTM standards
 - CS 23 amdt 4
 - CS VLA amdt 1
- The TLS will provide a “bridge” between F44 standards content and CAA regulatory requirements
- Unless we rescind a MOC, all MOCs that have been accepted are always accepted.
- If the applicant goes for an accepted MOC, no discussion or further coordination (CRI) should be required

Alternative MOC

- An applicant can always propose an alternate means of compliance to an existing accepted means of compliance.
- Applicants should carefully consider the additional time and effort that could be necessary to coordinate a new or alternate means of compliance when scheduling their projects.
- MOC CRIs might develop. Public consultation might also be considered.
- Standardization should be an objective:
 - New MOC driven into F44 standards
- FAA drafted an Advisory Circular for the Accepted Means of Compliance Process (AC 23.10)

Existing MOC

- Book 2 of CS 23, Part 23 ACs –
 - Remain in effect except for the areas of change of the technical content
 - Will need to use the cross reference table for section number
- alignment
 - Long term plan is to incorporate into F-44 documents like the old Civil Airworthiness Manuals for CAR 3

MOC List format example

- How an acceptable format of a MOC list could look like:

Requirement	Sub-para	Compliance Ref.	Compliance ref. Sect.	MOC	Method	Compliance Document	Doc. Status	Remarks / Comments / Statement	CDI	LOI
23.2140	Stability									
	(a)(1)	Ref. to consensus Standard or other AMC (old CS 23).	Ref. to Compliance Ref. subpara. Or section	0,6	Brief explanation of the method used for analysis or testing. Ref. to standard practice if any (FAA AC, EASA CM, Book2)	Document number, title and revision status supporting the compliance statement	Status of completion of the document	Any relevant remarks. Reason for non-applicability. Compliance statement	CDI no.	LOI code

ASTM format

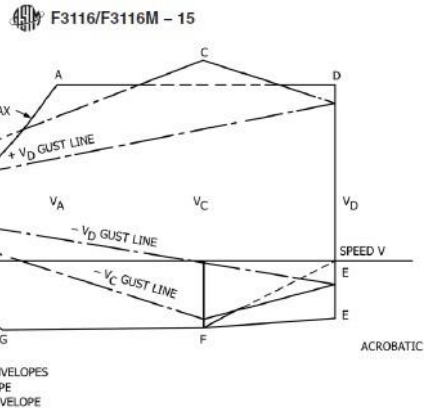

Note 1—Point G need not be investigated when the supplementary condition specified in 4.14 is investigated.

FIG. 1 Flight Envelope

4.5.1.1 $2.1 + \frac{24,000}{W + 10,000}$, where W = design maximum take-off weight (lb), except that n need not be more than 3.8;

4.5.1.2 6.0 for airplanes approved for aerobatics.

4.5.2 The negative limit maneuvering load factor may not be less than:

4.5.2.1 0.4 times the positive load factor;

4.5.2.2 0.5 times the positive load factor for airplanes approved for aerobatics.

4.5.3 Maneuvering load factors lower than those specified in this section may be used if the airplane has design features that make it impossible to exceed these values in flight.

4.6 Gust Load Factors:

4.6.1 Each airplane must be designed to withstand loads on each lifting surface resulting from gusts specified in 4.4.3.

4.6.2 The gust load factors for a canard or tandem wing configuration must be computed using a rational analysis, or may be computed in accordance with 4.6.3, provided that the resulting net loads are shown to be conservative with respect to the gust criteria of 4.4.3.

4.6.3 In the absence of a more rational analysis, the gust load factors must be computed as follows:

$$n = 1 + \frac{K U_g V_a}{498 \left(\frac{W}{S} \right)} \quad (2)$$

where:

- $K = \frac{0.88 \mu_x}{5.3 + \mu_x}$ = gust alleviation factor;
- $\mu_x = \frac{2(W/S)}{\rho C_{Dg}}$ = airplane mass ratio;

U_{de} = derived gust velocities referred to in 4.4.3 (f.p.s.).

- ρ = density of air (slugs/ft³);
- W/S = wing loading (p.s.f.) due to the applicable weight of the airplane in the particular load case;
- C = mean geometric chord (ft);
- g = acceleration due to gravity (ft/s²);
- V = airplane equivalent speed (knots); and
- a = slope of the airplane normal force coefficient curve $C_{N\alpha}$ per radian if the gust loads are applied to the wings and horizontal tail surfaces simultaneously by a rational method. The wing lift curve slope $C_{L\alpha}$ per radian may be used when the gust load is applied to the wings only and the horizontal tail gust loads are treated as a separate condition.

4.7 Design Fuel Loads:

4.7.1 The disposable load combinations must include each fuel load in the range from zero fuel to the selected maximum fuel load.

4.7.2 If fuel is carried in the wings, the maximum allowable weight of the airplane without any fuel in the wing tank(s) must be established as "maximum zero wing fuel weight," if it is less than the maximum weight.

4.7.3 For level 4 airplanes, a structural reserve fuel condition, not exceeding fuel necessary for 45 min of operation at maximum continuous power, may be selected. If a structural reserve fuel condition is selected, it must be used as the minimum fuel weight condition for showing compliance with the flight load requirements prescribed in this part and:

4.7.3.1 The structure must be designed to withstand a condition of zero fuel in the wing at limit loads corresponding to:

F3173/F3173M - 15

4.4.2.4 A speed equal to that at which compliance with 23.69(a) has been shown, and

4.4.2.5 All propeller controls in the position at which compliance with 23.69(a) has been shown.

4.4.3 For airplanes with a stall speed in the landing configuration of more than 45 knots, it shall be shown that the airplane is safely controllable without the use of the primary lateral control system in any all-engine configuration(s) and at any speed or altitude within the approved operating envelope. It shall also be shown that the airplane's flight characteristics are not impaired below a level needed to permit continued safe flight and the ability to maintain attitudes suitable for a controlled landing without exceeding the operational and structural limitations of the airplane. If a single failure of any one connecting or transmitting link in the lateral control system would also cause the loss of additional control system(s), compliance with the above requirement shall be shown with those additional systems also assumed to be inoperative.

4.5 Minimum Control Speed:

4.5.1 V_{MC} is the calibrated airspeed at which, when the critical engine is suddenly made inoperative, it is possible to maintain control of the airplane with that engine still inoperative and, thereafter, maintain straight flight at the same speed with an angle of bank of not more than 5°. The method used to simulate critical engine failure shall represent the most critical mode of powerplant failure expected in service with respect to controllability.

4.5.2 V_{MC} for takeoff shall not exceed:

4.5.2.1 For multi-engine airplanes with a $V_{SO} \leq 65$ kt and that during the climb demonstration in 23.67(a)(2) cannot climb after a critical loss of thrust, V_{S1} , where V_{S1} is determined for all practical weights and takeoff configurations.

4.5.2.2 For all other multi-engine airplanes, 1.2 V_{S1} , where V_{S1} is determined at the maximum takeoff weight.

4.5.3 V_{MC} shall be determined with the most unfavorable weight and center-of-gravity position and the airplane airborne and the ground effect negligible, for the takeoff configuration(s) with:

- 4.5.3.1 Maximum available takeoff power initially on each engine;
- 4.5.3.2 The airplane trimmed for takeoff;
- 4.5.3.3 Flaps in the takeoff position(s);
- 4.5.3.4 Landing gear retracted; and
- 4.5.3.5 All propeller controls in the recommended takeoff position throughout.

4.5.4 For all airplanes except low-speed Level 1 and 2 airplanes, the conditions of 4.5.1 shall also be met for the landing configuration with:

- 4.5.4.1 Maximum available takeoff power initially on each engine;
- 4.5.4.2 The airplane trimmed for an approach, with all engines operating, at V_{REF} , at an approach gradient equal to the steepest used in the landing distance demonstration of 23.75;
- 4.5.4.3 Flaps in the landing position;
- 4.5.4.4 Landing gear extended; and
- 4.5.4.5 All propeller controls in the position recommended for approach with all engines operating.

4.5.5 A minimum speed to render the critical engine inoperative intentionally shall be established and designated as the safe, intentional, one-engine-inoperative speed (V_{SSE}).

4.5.6 At V_{MC} , the rudder pedal force required to maintain control shall not exceed 667 N [150 lbf] and it shall not be necessary to reduce power of the operative engine(s). During the maneuver, the airplane shall not assume any dangerous attitude and it shall be possible to prevent a heading change of more than 20°.

4.5.7 At the option of the applicant, to comply with the requirements of 23.51(c)(1), V_{MCG} may be determined. V_{MCG} is the minimum control speed on the ground and is the calibrated airspeed during the takeoff run at which, when the critical engine is suddenly made inoperative, it is possible to maintain control of the airplane using the rudder control alone (without the use of nose wheel steering) as limited by 667 N [150 lbf] of force and using the lateral control to the extent of keeping the wings level to enable the takeoff to be safely continued. In the determination of V_{MCG} , assuming that the path of the airplane accelerating with all engines operating is along the centerline of the runway, its path from the point at which the critical engine is made inoperative to the point at which recovery to a direction parallel to the centerline is completed may not deviate more than 9.1 m [30 ft] laterally from the centerline at any point. V_{MCG} shall be established with:

- 4.5.7.1 The airplane in each takeoff configuration or, at the option of the applicant, in the most critical takeoff configuration;
- 4.5.7.2 Maximum available takeoff power on the operating engines;
- 4.5.7.3 The most unfavorable center of gravity position;
- 4.5.7.4 The airplane trimmed for takeoff; and
- 4.5.7.5 The most unfavorable weight in the range of takeoff weights.

4.6 Aerobatic Maneuvers—Each aerobatic airplane shall be able to perform safely the aerobatic maneuvers for which certification is requested. Safe entry speeds for these maneuvers shall be determined.

4.7 Control during Landings—It shall be possible, while in the landing configuration, to complete a landing safely without exceeding the one-hand control force limits specified in Table 1 following an approach to land:

- 4.7.1 At a speed of V_{REF} minus 5 knots;
- 4.7.2 With the airplane in trim, or as nearly as possible in trim and without the trimming control being moved throughout the maneuver;
- 4.7.3 At an approach gradient equal to the steepest used in the landing distance demonstration; and
- 4.7.4 With only those power changes, if any, that would be made when landing normally from an approach at V_{REF} .

4.8 Elevator Control Force in Maneuvers:

4.8.1 The elevator control force needed to achieve the positive limit maneuvering load factor shall not be less than:

the procedure and meeting the flight characteristics specified in the appropriate stall handling characteristics testing.

4.3 Takeoff Speeds:

4.3.1 The rotation speed, V_R , is the speed at which the pilot makes a control input with the intention of lifting the aeroplane out of contact with the runway or water surface.

4.3.1.1 For low-speed Levels 1, 2, and 3 multiengine landplanes, V_R shall not be less than the greater of $1.05 V_{MC}$ or $1.10 V_{S1}$.

4.3.1.2 For single-engine landplanes, V_R shall not be less than V_{S1} .

4.3.1.3 For seaplanes and amphibians taking off from water, V_R may be any speed that is shown to be safe under all

airspeed, shall be selected than the greatest of the following:

(1) V_1 ;

(2) $1.05 V_{MC}$ determined

(3) $1.10 V_{S1}$; or

(4) The speed that a speed, V_2 , before reaching takeoff surface in accordance with

4.3.3.3 For any given altitude, temperature, and shall be used to show compliance with inoperative takeoff and landing requirements.

Reference to the main section of the consensus standard could be sufficient implying that subsections are applied as well (except otherwise specified in the remarks column)

Compliance Matrix Approach

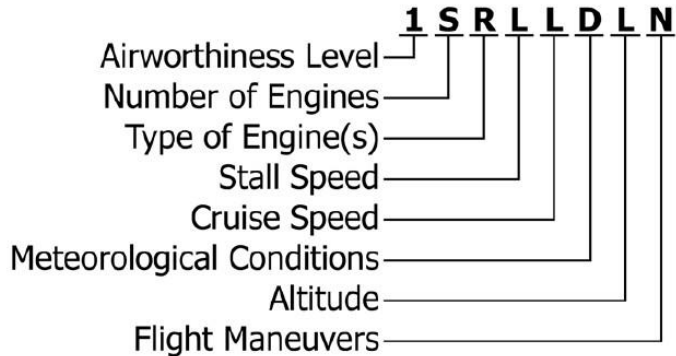

Aircraft Type Code

- An empty cell () in all applicable ATC character field columns indicates that an aircraft must meet the requirements of that subsection.

TABLE 1 ATC Compliance Matrix, Section 4

Section	Airworthiness Level				Number of Engines		Type of Engine(s)		Stall Speed			Cruise Speed		Meteorological Conditions			Altitude		Maneuvers	
	1	2	3	4	S	M	R	T	L	M	H	L	H	D	N	I	L	H	N	A
4																				
4.1																				
4.1.1																				
4.1.2																				
4.1.3																				
4.1.4																				
4.1.5																				
4.1.6	o								o					o						
4.1.7																				
4.1.8																				
4.1.8.1																				
4.1.8.2																				
4.2																				
4.2.1																				
4.2.1.1		x	x	x						x	x				x	x				
4.2.1.2	o								o					o						
4.2.1.3	o								o					o						
4.2.1.4	o								o					o						
4.2.2	o								o					o						
4.2.2.1	o								o					o						
4.2.2.2	o								o					o						
4.2.2.3	o								o					o						
4.2.2.4	o								o					o						
4.2.2.5	o								o					o						
4.2.3	o								o					o						
4.2.3.1	o								o					o						
4.2.4									o					o						
4.2.4.1									o					o						
4.2.4.2									o					o						

- A white circle (o) in multiple columns indicates that an aircraft is exempt from the requirements of that subsection *only* if all such ATC character fields are applicable.

- A mark-out (x) in any of the applicable ATC character field columns indicates that an aircraft is exempt from the requirements of that subsection.

MOC List format example

Requirement	Sub-para	Compliance ref	Compliance ref. section	MOC	Method	Compliance Document	Doc. Status	Remarks / Comments / Statement	LOI
23.2200 Structural design envelope									
		F3116-15	4.4 Flight envelope 4.5 Limit maneuvering load factors 4.6 Gust load factors	2	Gust load factors are calculated using formulas in F3116 (4.6.3)	LA-EASA-000014 Loads Flight Envelope		Requirements for aerobatics, level 4, canard and tandem wing aeroplanes are not considered.	
	(a)(1)	F3116-15	5.1 Design Airspeeds	2	V_d is calculated as $1.4V_c$	LA-EASA-000010 Flight loads			
	(a)(2)	F3174-15	4.2 Airspeed limitations 4.3 Operating Maneuvering Speed 4.4 Flap Extended Speed	1,2	Calculation based on the design speeds derived using F3116-15	DE-EASA-000001 Main datasheet			
	(b)			0				Flight load conditions expected in service are considered by showing compliance to 23.2225	
	(c)	F3116-15	4.2 Flight loads – General	2	Variation from design minimum to maximum weight will be considered in loads determination	LA-EASA-000014 Loads Flight Envelope Rev. 0			
	(d)	F3116-15	4.5 Limit maneuvering load factors	2		LA-EASA-000014 Loads Flight Envelope Rev. 0			
	(e)	F3116-15	4.1.3 Flight loads - Loads	0	Engineering judgement.			Deflections under loads are of minor magnitude for the given aeroplane configuration.	
23.2205 Interaction of systems and structures									

CRI A-01

Standard point in CRI A-01:

5. Interpretative Material / Means of Compliance

In addition to the regulatory basis noted in the above sections, EASA is adopting certain “Acceptable Means of Compliance” in several CRI’s. These CRI’s here are used to develop means of compliance acceptable to EASA for several subject areas.

These acceptable means of compliance are used for EASA certification activities of the aeroplane type applied for, as well as for post-type certification design changes, and are listed following the proposed certification basis.

Streamlining the process

- MOCs can replace the current process of SCs and ELOSs for specific technologies reducing administrative burden
- Currently ca. 90 “standard” CRIs (SC, ELOS and MOC) are identified and applied to type investigations when required by the aircraft design
- Long term plan: ASTM standards to incorporate all of these additional requirements

Some examples

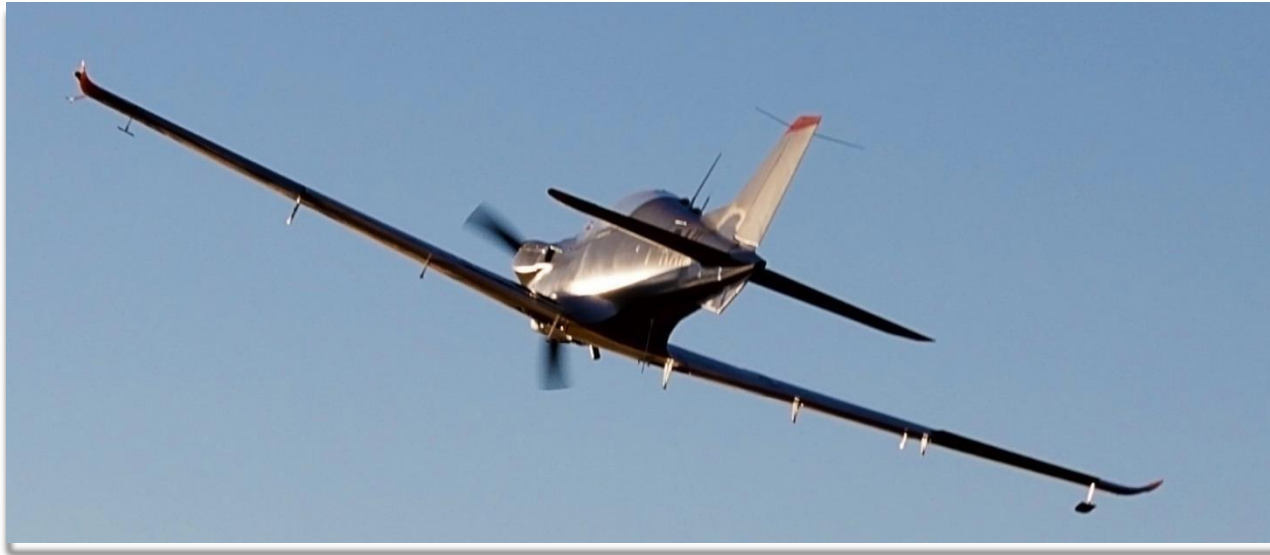

Current Requirement – CS-VLA

- Special Condition IFR
- Special Condition Aerobatics
- Special Condition BRS
- ELOS – fuel selector “BOTH”

Future Requirement – CS-23 amdt 5

All covered by Consensus Standards

Some examples



Current Requirement – CS-23

- Special Condition Human Factor aspects
- Special Condition Lithium Battery
- Several MOC CRIs

Future Requirement – CS-23 amdt 5

All covered by Consensus Standards

Some examples



The certification basis of the PC-24 includes more than **100 CRI**
Even if the reorganised CS 23 gives no relief concerning technical investigation, the amount of work to administrate that high number of CRI would be saved for a great benefit to all parties

End of the process - TCDS

➤ Current information in the TCDS:

- Airworthiness Category: Utility and Aerobatic
- Airworthiness Requirements: CS-23 amdt 1

➤ Proposed additions:

- Aeroplane certification level: Level 1
- Aeroplane performance level: High speed
- Airworthiness requirements: CS-23 amdt 5
- Top Level Specification: TLS revision XX

ATC might be mentioned when compliance matrix approach is used