



**Australian Government**  
**Civil Aviation Safety Authority**



## **C404 VH-ANV accident and CASA changes**

*May 2018*



# Contents

- CAR 35
- C404 VH-ANV accident – 11 Aug 2003
- ATSB Investigation – report Mar 2005
- Coronial Inquest – findings Dec 2005
- CASA AEB reforms – 2007 onwards
- CASR Subpart 21.M – June 2011

## ***Civil Aviation Regulations 1988***

### **35 Approval of design of modification or repair**

- (1) A person may apply to CASA or an authorised person for approval of the design of a modification or repair of:
  - (a) an aircraft or aircraft included in a type of aircraft; or
  - (b) an aircraft component or aircraft components included in a type of aircraft component.
  
- (2) Where an applicant under subregulation (1):
  - (a) furnishes to CASA or the authorised person such evidence relating to the design to which the application relates (including evidence of the effect of the design on the safety of an aircraft) as CASA or the authorised person requires; and
  - (b) **satisfies CASA or the authorised person that the design conforms with any relevant design standard in respect of the type of aircraft or aircraft component to which the application relates;**

CASA or the authorised person shall give approval to the design.





# C404 VH-ANV accident



- Cessna 404, VH-ANV
- 1 Pilot plus 5 pax
- Aerial work

- Failure of right hand engine on takeoff
- Aircraft crash landed in lightly wooded terrain, rupturing the fuel tanks resulting in post crash fire
- 1 pax fatally injured in crash and fire
- Pilot and remaining pax sustained serious burns
- 1 pax died of injuries 85 days later



FIGURE 1: Aerial photograph<sup>4</sup> of Jandakot Airport with ATS radar data overlaid

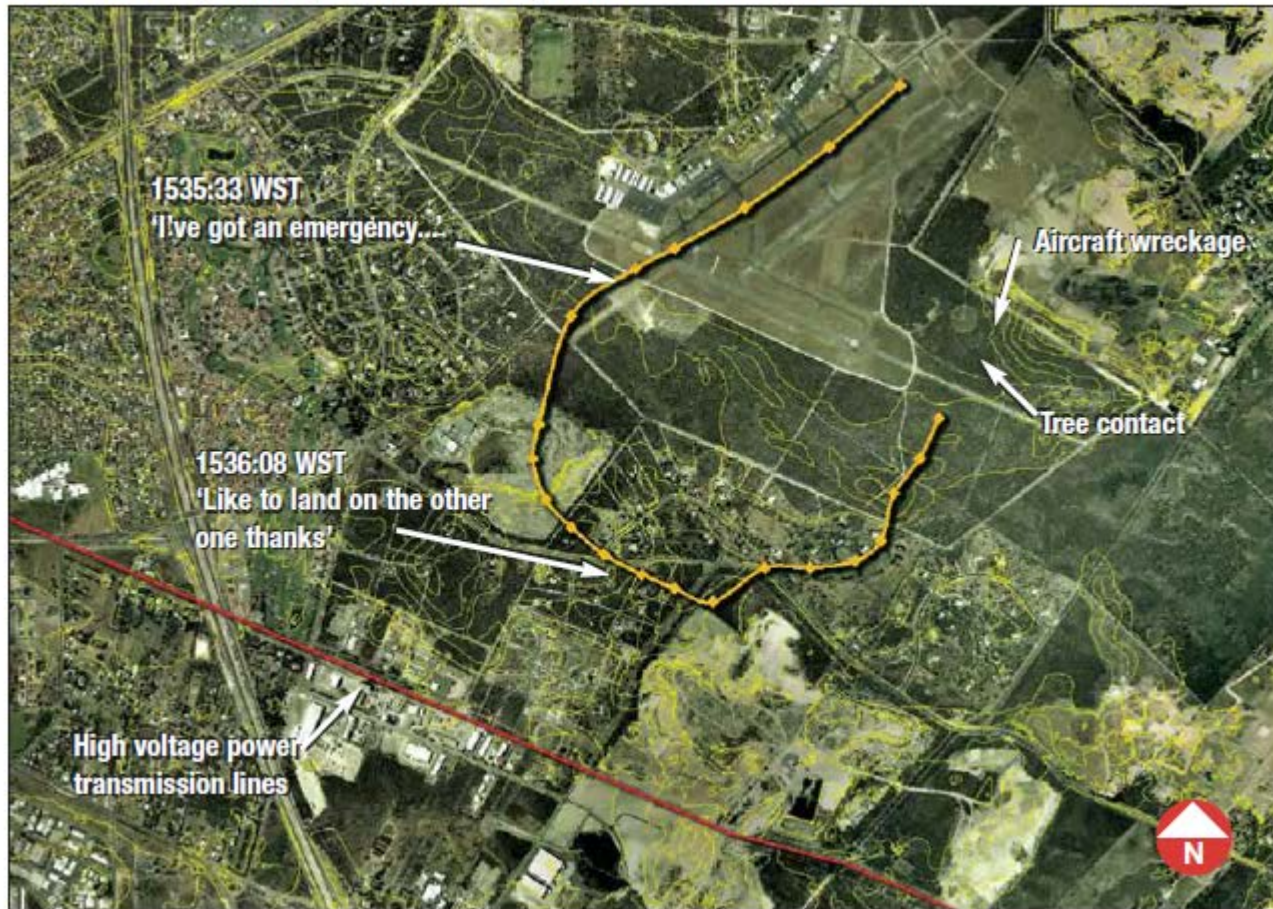

**FIGURE 2: Initial impact with trees, looking back along the aircraft's flight path**





# ATSB Findings

## Safety Investigation 200303579, March 2005

“Examination of the right engine revealed a material anomaly with the sleeve bearing from the engine-driven fuel pump. That bearing exhibited evidence of localised adhesive wear (galling) that had restricted the rotation of the pump spindle shaft. The bearing had previously been replaced during the last engine overhaul. Analysis of the bearing revealed that it had been manufactured from material that possessed inferior galling resistance when compared with bearings from similar pumps. The investigation concluded that the specified material for the replacement sleeve bearing was inadequate with respect to its galling resistance. High torsional loads between the spindle shaft and the sleeve bearing had caused the pump’s drive shaft to shear at a critical phase of flight. Associated with a loss of drive to the pump shaft was a reduction in fuel pressure, which was insufficient to sustain operation of the engine at take-off power.”



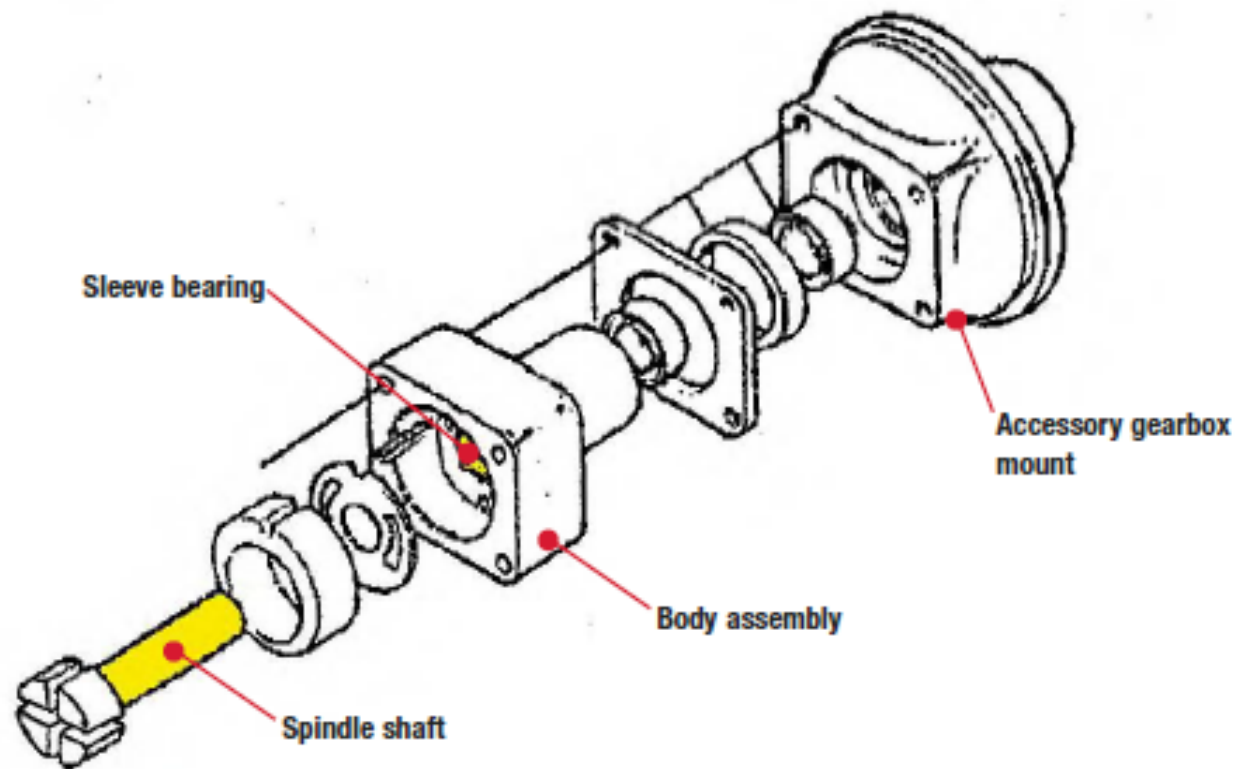

“The process of producing the engineering order did not identify that the original equipment manufacturer (OEM) specification was for the use of high leaded bronze in bearing manufacture.”

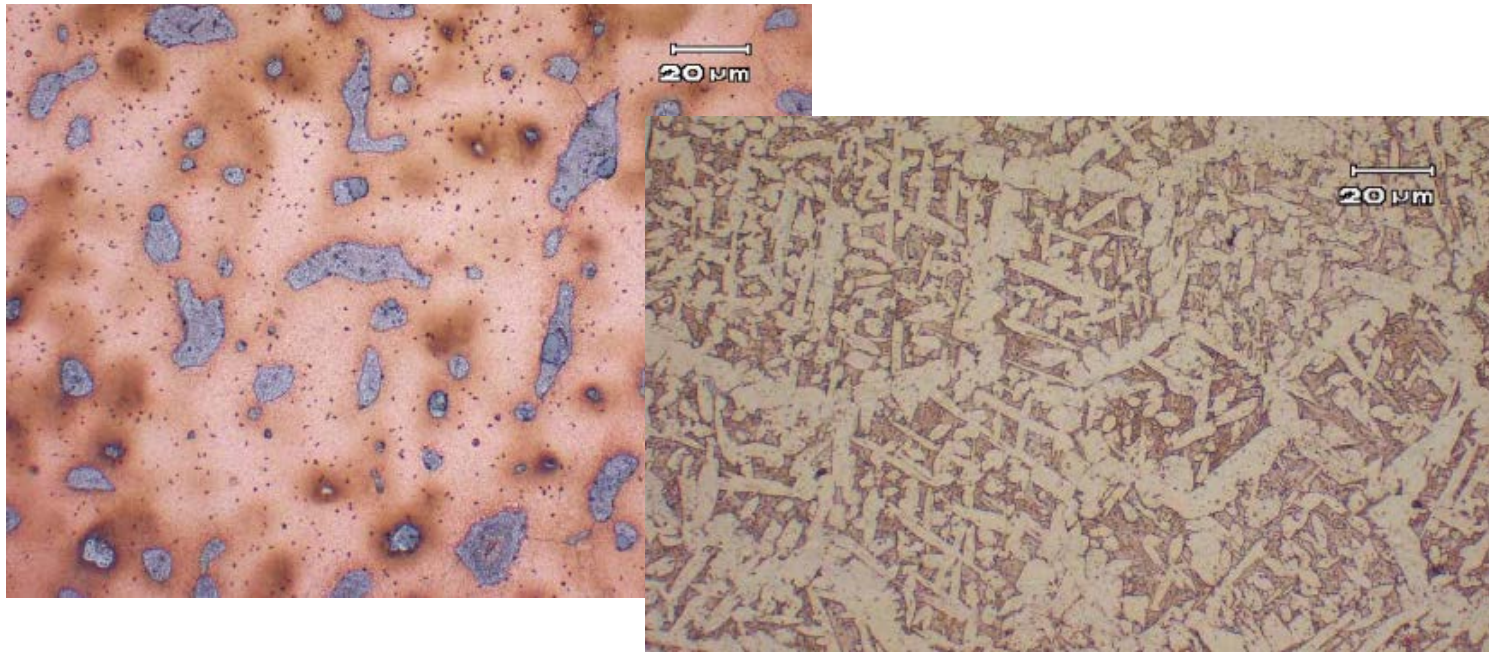

# Coronial Inquest Findings – Dec 2005

## Recommendations re CAR 35

1. That in future CASA ensure that reasonably comprehensive audits are in fact conducted in respect of all CAR 30 organisations and CAR 35 authorised persons on a regular basis of no more than 24 months duration.
2. That CASA require its CAR 30 design organisations and CAR 35 authorised persons to ensure that engineering orders contain sufficient information in each case to provide a clear indication as to the basis of the engineering order and specify whether the engineering order is proposing a “like for like” replacement or the construction of an entirely new item. In the event that an engineering order is approving a material change, the relevant file should contain a metallurgical report providing information in relation to the material in question.



# Coronial Inquest Findings – Dec 2005

## Recommendations re CAR 35

3. That in the event that CAR 35 authorised persons or CAR 30 design organisations do not prepare engineering orders containing sufficient information, then consideration should be given to not permitting those persons or organisations to continue to exercise those functions.
6. That CASA should review the process for issuing engineering orders which relate to aircraft to ensure that those who own, operate or maintain any aircraft effected by an engineering order receive a copy of that order irrespective of whether or not those parties commissioned the engineering order

*Sec. 23.603/33.15 Materials*

*(a) The suitability and durability of materials used for parts, the failure of which could adversely affect safety, must--*

- (1) Be established by experience or tests;*
- (2) Meet approved specifications that ensure their having the strength and other properties assumed in the design data; and*
- (3) Take into account the effects of environmental conditions, such as temperature and humidity, expected in service.*

## Compliance Table

23.603	Materials	All materials specified in the engineering order comply with standard aviation specifications
--------	-----------	---





*Sec. 23.603/33.15 Materials*

*(a) The suitability and durability of materials used for parts, the failure of which could adversely affect safety, must--*

*(1) Be established by experience or tests;*

*(2) Meet approved specifications that ensure their having the strength and other properties assumed in the design data; and*

*(3) Take into account the effects of environmental conditions, such as temperature and humidity, expected in service.*

## Compliance Table

23.603	Materials	All materials specified in the engineering order comply with standard aviation specifications
--------	-----------	---



Sec. 23.603/33.15 *Materials*

(a) *The **suitability and durability** of materials used for parts, the failure of which could adversely affect safety, must--*

(1) *Be established by **experience or tests**;*

(2) ***Meet approved specifications** that ensure their having the **strength and other properties assumed in the design data**; and*

(3) *Take into account the effects of **environmental conditions**, such as temperature and humidity, expected in service.*



## Compliance Table

23.603	Materials	All materials specified in the engineering order comply with standard aviation specifications
--------	-----------	---



# CASA AEB reforms (Design IOA Procedures Manual)

## **CAR 35 Design Approval Procedures Manual**

- Clear specification of technical speciality and scope
- Clear definition of the design approval process
- Clarification of Design Advice role (major/minor classification)
- Statement of Compliance on CASA Form 979
- Compliance summary addressing relevant clauses of the applicable airworthiness standard
- Activity reporting at defined intervals
- Standardisation across all CAR 35 Instrument of Appointment Holders (IOAH)

# CASA AEB reforms (Design IOA Procedures Manual)

## Entry Control

- Minimum qualifications
  - 4 year engineering degree
- Minimum experience
  - 4 years relevant postgraduate
  - samples of work
- Knowledge test
  - interview with CASA regulatory and technical specialists
- Basis of appointment recorded in SFR process



# CASA AEB reforms (Design IOA Procedures Manual)

## Surveillance

- risk based
  - level of activity
  - proportion of transport category
  - complexity of mods/repairs
  - previous audit findings
- maximum audit frequency defined in CSM
- reports stored in RM8 surveillance file for each organisation
- Sky Sentinel





# CASR Subpart 21.M – Modifications and Repairs

- Applicable airworthiness standard based on TCDS certification basis
  - special conditions
  - non-applicable airworthiness standards
- Test requirements
  - test article conformity
  - equipment calibration
- Mandatory approval of technical data under 21.009
  - **demonstration of compliance**
- No unsafe feature or characteristic



# QUESTIONS?

